

Panasonic®

Operating Instructions

LCD Video Monitor

Model No. **BT-LH910G**

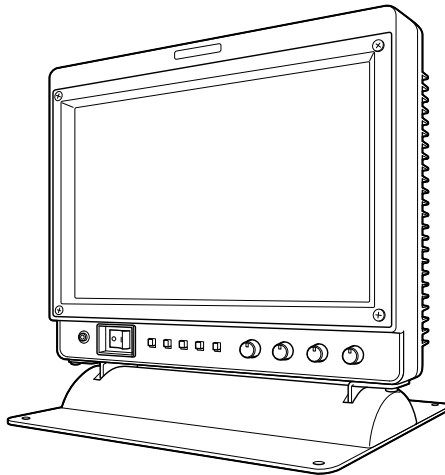

HDMI™
HIGH DEFINITION MULTIMEDIA INTERFACE

Before operating this product, please read the instructions carefully and save this manual for future use.

Read this first !

 indicates safety information.

- **DO NOT REMOVE PANEL COVERS BY UNSCREWING THEM.**
No user serviceable parts inside.
Refer servicing to qualified service personnel.

WARNING:

- To reduce the risk of fire, do not expose this equipment to rain or moisture.
- To reduce the risk of fire hazard, keep this equipment away from all liquids. Use and store only in locations which are not exposed to the risk of dripping or splashing liquids, and do not place any liquid containers on top of the equipment.

WARNING:

Always keep the tilt stand mounting screws and protection panel screws out of the reach of infants and small children.

CAUTION:

Excessive sound pressure from earphons and headphones can cause hearing loss.

CAUTION:

To reduce the risk of fire and annoying interference, use the recommended accessories only.

CAUTION:

In order to maintain adequate ventilation, do not install or place this unit in a bookcase, built-in cabinet or any other confined space.
To prevent risk of fire hazard due to overheating, ensure that curtains and any other materials do not obstruct the ventilation.

FCC NOTICE (USA)

This device complies with part 15 of the FCC Rules. Operation is subject to the following two conditions:

(1) This device may not cause harmful interference, and (2) this device must accept any interference received, including interference that may cause undesired operation

CAUTION:

This equipment has been tested and found to comply with the limits for a class A digital device, pursuant to Part 15 of the FCC Rules. These limits are designed to provide reasonable protection against harmful interference when the equipment is operated in a commercial environment. This equipment generates, uses, and can radiate radio frequency energy and, if not installed and used in accordance with the instruction manual, may cause harmful interference to radio communications. Operation of this equipment in a residential area is likely to cause harmful interference in which case the user will be required to correct the interference at his own expense.

Warning:

To assure continued FCC emission limit compliance, the user must use only shielded interface cables when connecting to external units. Also, any unauthorized changes or modifications to this equipment could void the user's authority to operate it.

Notice (U.S.A. only):

Disposal may be regulated in your community due to Environmental considerations. For disposal or recycling information, please visit Panasonic website: <http://www.panasonic.com/environmental> or call 1-888-769-0149.

EEE Yönetmeliğine Uygundur.
EEE Complies with Directive of Turkey.

A rechargeable battery that is recyclable powers the product you have purchased.

EMC NOTICE FOR THE PURCHASER/USER OF THE APPARATUS

1. Applicable standards and operating environment

The apparatus is compliant with:

- standards EN55103-1 and EN55103-2 2009, and
- electromagnetic environments E1, E2, E3 and E4.

2. Pre-requisite conditions to achieving compliance with the above standards

<1> Peripheral equipment to be connected to the apparatus and special connecting cables

- The purchaser/user is urged to use only equipment which has been recommended by us as peripheral equipment to be connected to the apparatus.
- The purchaser/user is urged to use only the connecting cables described below.

<2> For the connecting cables, use shielded cables which suit the intended purpose of the apparatus.

- Video signal connecting cables

Use double shielded coaxial cables, which are designed for 75-ohm type high-frequency applications, for SDI (Serial Digital Interface).

Coaxial cables, which are designed for 75-ohm type high-frequency applications, are recommended for analog video signals.

- Audio signal connecting cables

If your apparatus supports AES/EBU serial digital audio signals, use cables designed for AES/EBU.

Use shielded cables, which provide quality performance for high-frequency transmission applications, for analog audio signals.

- Other connecting cables (IEEE1394, USB)

Use shielded cables, which provide quality performance for high-frequency applications, as connecting cables.

- When connecting to the DVI signal terminal, use a cable with a ferrite core.
- If your apparatus is supplied with ferrite core(s), they must be attached on cable(s) following instructions in this manual.

3. Performance level

The performance level of the apparatus is equivalent to or better than the performance level required by these standards.

However, the apparatus may be adversely affected by interference if it is being used in an EMC environment, such as an area where strong electromagnetic fields are generated (by the presence of signal transmission towers, cellular phones, etc.). In order to minimize the adverse effects of the interference on the apparatus in cases like this, it is recommended that the following steps be taken with the apparatus being affected and with its operating environment:

1. Place the apparatus at a distance from the source of the interference.
2. Change the direction of the apparatus.
3. Change the connection method used for the apparatus.
4. Connect the apparatus to another power outlet where the power is not shared by any other appliances.

Pursuant to at the directive 2004/108/EC, article 9(2)

Panasonic Testing Centre

Panasonic Service Europe, a division of Panasonic Marketing Europe GmbH

Winsberger 15, 22525 Hamburg, F.R. Germany

IMPORTANT SAFETY INSTRUCTIONS

- 1) Read these instructions.
- 2) Keep these instructions.
- 3) Heed all warnings.
- 4) Follow all instructions.
- 5) Do not use this apparatus near water.
- 6) Clean only with dry cloth.
- 7) Do not block any ventilation openings. Install in accordance with the manufacturer's instructions.
- 8) Do not install near any heat sources such as radiators, heat registers, stoves, or other apparatus (including amplifiers) that produce heat.
- 9) Do not defeat the safety purpose of the polarized or grounding-type plug. A polarized plug has two blades with one wider than the other. A grounding-type plug has two blades and a third grounding prong. The wide blade or the third prong are provided for your safety. If the provided plug does not fit into your outlet, consult an electrician for replacement of the obsolete outlet.
- 10) Protect the power cord from being walked on or pinched particularly at plugs, convenience receptacles, and the point where they exit from the apparatus.
- 11) Only use attachments/accessories specified by the manufacturer.
- 12) Use only with the cart, stand, tripod, bracket, or table specified by the manufacturer, or sold with the apparatus. When a cart is used, use caution when moving the cart/ apparatus combination to avoid injury from tip-over.
- 13) Unplug this apparatus during lightning storms or when unused for long periods of time.
- 14) Refer all servicing to qualified service personnel. Servicing is required when the apparatus has been damaged in any way, such as power-supply cord or plug is damaged, liquid has been spilled or objects have fallen into the apparatus, the apparatus has been exposed to rain or moisture, does not operate normally, or has been dropped.



Transportation precautions

Do not try to lift the monitor by grabbing the panel.

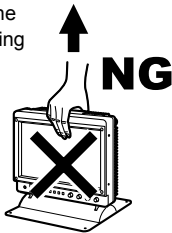

Do not place the monitor face down during transportation to prevent damaging it. Keep it upright.

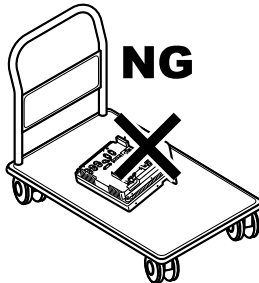

Do not expose the LCD panel to strong pressure or pressure from pointed objects. Take care especially during transportation.

Exposing the LCD panel to strong pressure may result in blurring or other damage.

Contents

Read this first !	2	Main Menu	24
Transportation precautions	4	Menu configuration	24
Standard accessories · Optional units	5	2D/3D ASSIST	25
About this instruction manual	5	MARKER	25
Precautions for Use	6	Types of MARKER	28
Request	6	VIDEO CONFIG	30
Outline	7	SYSTEM CONFIG	34
Selecting Area of Use	8	Performing AUTO CALIBRATION	36
Dimensions	9	RESET operation	37
Controls and Their Functions	10	VF CONFIG	37
Front panel	10	FUNCTION	38
Rear panel	13	GPI	47
Supplying the power	14	INPUT SELECT	48
Using an Anton/Bauer battery	14	AUDIO	49
Using a V-mount type battery	14	DISPLAY SETUP	50
Using an external DC power supply	15	CONTROL	51
VF Function	16	HOURS METER	51
How to Remove the Tilt Stand	17	3D Assist Mode	52
On-screen Display	18	MIRROR	
Operating status display	18	(Left/Right and Top/Bottom inversion)	54
Picture and volume adjusting knobs status display	19	SHIFT (Horizontal and Vertical Shift)	54
Sharpness display	19	COMPARISON (Composition Check)	54
Function display	19	CONVERGENCE (Convergence Check)	55
Audio level meter display	20	COLOR (Color Check)	55
Time code (TC) display	20	ZOOM FOCUS (Zoom and Focus Check)	56
Closed caption (CC) display	21	VERTICAL (Vertical Offset Check)	57
DC power supply voltage and battery level display	21	OVERLAY (Parallax Check)	58
How to Use the On Screen Menu	22	Setting Item Restrictions	59
Menu display	22	REMOTE Specifications	62
Menu operations	22	GPI terminal	62
User Data	23	SERIAL terminal	64
Saving user data	23	VF (viewfinder) Specifications	68
Loading user data	23	Error and Warning Displays	69
		Maintenance	69
		Specifications	70

Standard accessories · Optional units

■ Standard accessories

- Tilt Stand × 1
 - Tilt Stand Mounting Screw × 4
 - CD-ROM × 1
- (The unit is shipped with the tilt stand already attached with the four screws.)

■ Optional units

- VF Cable BT-CS910G

About this instruction manual

- This instruction manual refers to BT-LH910G as “this unit.”
- The illustrations, explanatory drawings, and other figures included in this instruction manual are for illustrative purposes only and may differ from actual display.
- HDMI, the HDMI logo, and High-Definition Multimedia Interface are trademarks or registered trademarks of HDMI Licensing, LLC in the United States and/or other countries.

Precautions for Use

This product has been specially designed for commercial use. As such, it should be used and operated only by persons with related expertise.

- The LCD screen is manufactured to precise specifications. Although over 99.99 % of the pixels function normally, 0.01 % of the pixels are either missing or constantly lit (red, blue or green). This is normal and not a cause for concern.
- The protection panel and liquid crystal panel is a specially manufactured component. Wiping it with a hard cloth, or rubbing it vigorously will scratch the surface.
- If a still image is displayed for an extended period of time, it may generate a temporary afterimage (phosphor burn-in). (However, such images can be removed by displaying normal video for a while.)
- The response speed and brightness of liquid crystal vary with ambient temperatures.
- Do not install the unit in locations where enough space cannot be provided around it as heat may build up inside preventing normal operation. Be sure to provide enough space around the unit.
- Exposing the LCD screen to intense light sources will impair its characteristics and lower image quality.
- In an environment exposed to drastic temperature fluctuations, condensation may build up on and inside the LCD screen. This may lower the quality of the screen and may damage it. If there are drops of water on the case, turn off the power and wait until the condensation has evaporated.
- Some video images may appear blurred on the screen.
- Leaving the unit in a location exposed to high temperature and humidity for an extended period of time may damage the LCD screen and cause blurring.
- Do not use the unit in excessively dusty environments. Doing so may damage the LCD screen.
- Using the unit in cases such as the following may result in image and audio distortion due to the influence of electromagnetic waves.
 - When in the vicinity of a TV or computer
 - When a mobile phone is on top of the unit
 - When near equipment that generates a power magnetic field, such as a speaker or large motor
- If the unit becomes unable to operate properly due the influence of equipment that generates magnetism, turn off the unit (if using a battery, remove it) and then wait a while and then turn it back on.
- Using the unit near radio broadcast equipment or high-voltage equipment may result in image and audio degradation.

Request

Please configure the following setting before using the unit for the first time.

- The unit is shipped with the area of use set to the initial state. Before using the unit, set your area of use as described in “Selecting Area of Use” on page 8.

Outline

This unit is a liquid crystal display monitor for broadcasting and business use that is equipped with a 23 cm (9.0 inch) (effective display area) liquid crystal display. It can be used as a VF (viewfinder) for broadcasting and business cameras made by Panasonic.

■ High Performance Liquid Crystal Panel

This product incorporates a WXGA (1280 x 768) class high-resolution IPS liquid crystal panel. It offers excellent color reproduction, a wide viewing angle, and a fast response time.

■ Superb Moving Image Quality Achieved by New Image Processing Engine

- The 10-bit image processing engine facilitates accurate and smooth gradation results from low to high brightness levels.
- The incorporation of an I/P conversion circuit with a low delay of less than one field minimizes the delay time between signal input and monitor display.
- The incorporation of diagonal line compensation circuit reduces image degradation in the vertical direction and jagged noise on diagonal lines.
- The high-speed moving image response time provides vivid and clear image display.
- Gamma compensation is performed for each monitor.

■ Includes 3D Assist Functions

Various assist functions are included to allow connecting the left and right connectors of a 3D camera to the two SDI inputs and capturing 3D images that are easier to view on a 2D monitor. These functions also make camera adjustments easier and reduce the preparation time required for 3D shooting.

■ Wide Variety of Functions and Interfaces

- Equipped with 3G-SDI, SDI (HD/SD compatible), HDMI, VIDEO, and YP_BP_R inputs.
- FOCUS-IN-RED function (Displayed abbreviated to F-IN-R in the picture adjusting knob status display.)
Making camera focus adjustments is extremely easy because the section of the image in focus is displayed in red to make it easy to understand what is in focus.
- WFM (Y/R/G/B) and vectorscope display functions
Capable of input signal Y/R/G/B waveform display (when 3G-SDI, SDI, HDMI, VIDEO, or YP_BP_R input) and vectorscope display.
- Audio level meter display function and headphones jack
The level of audio signals embedded in 3G-SDI, SDI, and HDMI signals can be displayed. Furthermore, support is also included for reference point setting, peak hold, and overrange display. The incorporation of a headphones jack means you can check the audio. The channel can also be selected in a menu.
- Closed caption function
The captions added to video signals can be displayed during SDI and VIDEO input.
- 2-screen display function
The screen can be split into two to allow you to make a screen comparison for the same input connectors and same format.
- PIXEL TO PIXEL function
This function makes camera focus adjustment extremely easy because the input signals are displayed without being resized.
When resizing is not performed, the 1080/60i signals can be expanded to the equivalent of an approximately 13.5-inch wide monitor, and then checked.
- Cross hatch display function
This function displays markers at regular vertical and horizontal intervals to facilitate easy composition.

Selecting Area of Use

The unit is shipped with the area of use set to the initial setting (NTSC) state. Before using the unit, select the area of use. When you set the area of use, the factory default setting of the menu item on the right is set to the value that matches the area of use. (For the procedure to restore the menu setting values to the factory defaults, refer to “Loading user data” on page 23.)

Menu Item \ AREA SETTING	NTSC	NTSC (J)	PAL
COLOR SPACE	SMPTE-C	EBU	EBU
HEAD ROOM	20 dB	20 dB	18 dB

How to Select Area of Use

- 1. Connect the unit to the power supply, turn on the power, and press the [MENU] button.**

The MAIN MENU screen appears.

- 2. Press [V][^] to select “SYSTEM CONFIG” and press [ENTER].**

The “SYSTEM CONFIG” submenu screen appears.

- 3. Press [V][^] to select “AREA SETTING” and press [ENTER].**

The “AREA SETTING” value turns green.

- 4. Press [V][^] to select the area of use from “NTSC/NTSC (J)/PAL” and press [ENTER].**

The “YES/NO” confirmation screen appears.

- 5. Press [V][^] to select “YES” and press [ENTER].**

The setting selected in step 4 is reflected in the factory defaults (FACTORY) or the current menu setting values and the “SYSTEM CONFIG” submenu screen appears.

- 6. Press [MENU] twice to close the menu.**

Dimensions

Unit: mm(inches)

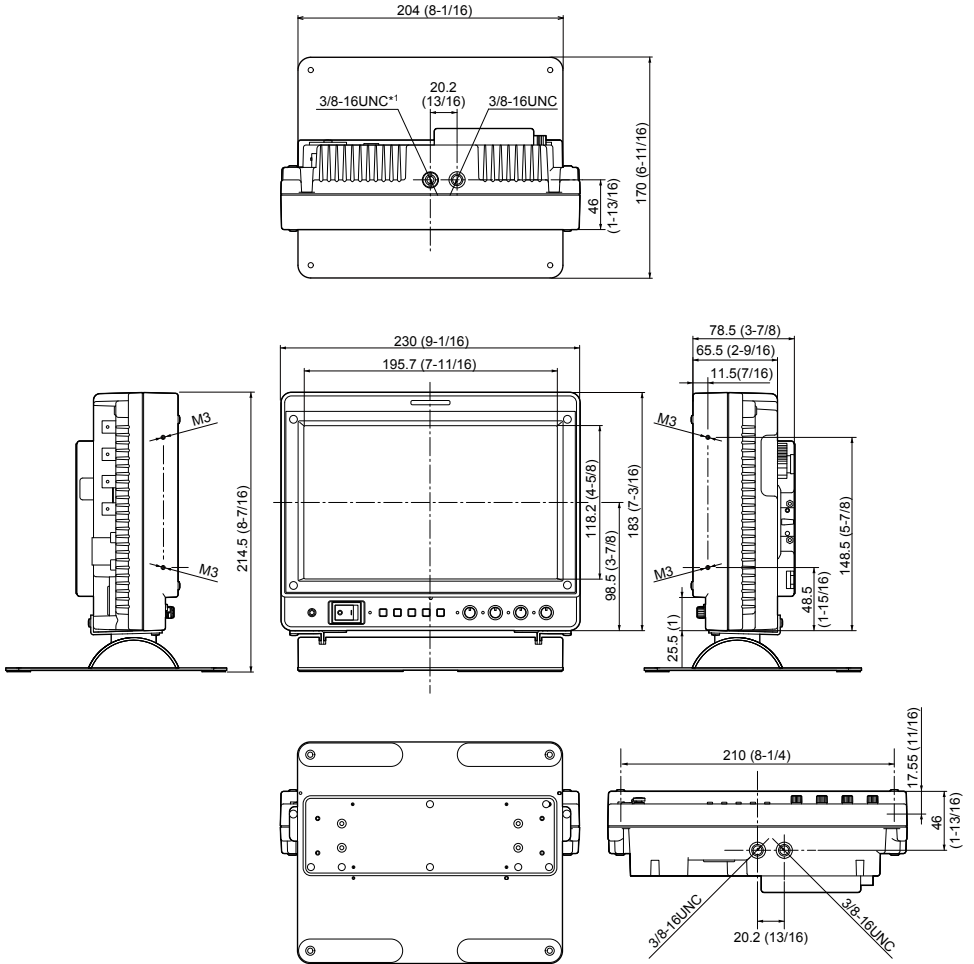

*1 When the adapter is connected: 1/4-20UNC

Controls and Their Functions

Front panel

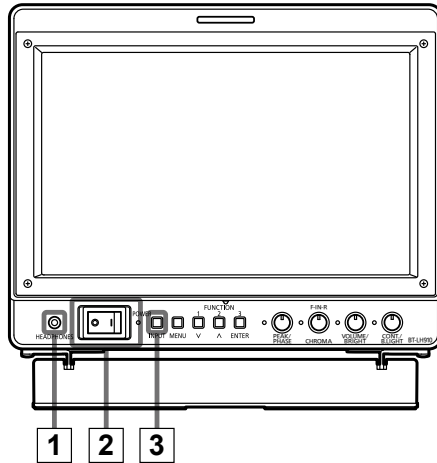

1 HEADPHONES output jack (M3 stereo mini jack)

Allows you to connect headphones to check the audio when inputting an SDI signal or HDMI signal.

* The volume and sound quality differ depending on the headphones.

- In 3D assist mode, the audio of the SDI1 (L) side can be checked.

2 POWER switch/lamp

Switches the power supply ON/OFF. When the power is ON, the LED (green) lights up.

3 INPUT SELECT button

Selects the signal input line. Each time the button is pressed, the input changes in the following order:

VIDEO → SDI1 → SDI2 → HDMI → YP_BP_R → VF → INT SG

VIDEO : Video input

SDI1 : Serial digital interface input (compatible with 3G/HD/SD)

SDI2 : Serial digital interface input (compatible with HD/SD)

HDMI : HDMI input

YP_BP_R : Analog component input

VF : Viewfinder input (VF-YP_BP_R / VF-VIDEO) *1

INT SG: Internal chart for adjustment [Color Bar + Grayscale] (page 74)

- The input line when the power supply is switched ON is the one that was selected the last time the power was switched OFF. The INPUT SELECT menu settings can be used to skip input lines that are not used.
- In 3D assist mode, the input is fixed to SDI1/SDI2 and the input line cannot be selected.
- When the control lock is on, input lines cannot be selected.
- It is not possible to switch to INT SG when two screens are displayed with the SUB WINDOW function (→ page 42).

*1 The menu is used to set either YP_BP_R or VIDEO for the viewfinder input.

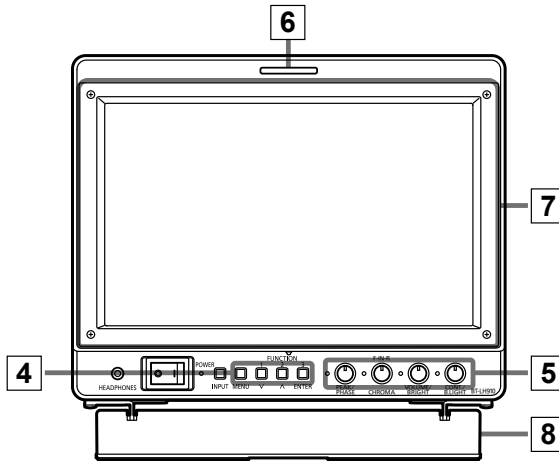

4 MENU, FUNCTION buttons

Use these buttons to display menus, select and adjust settings and confirm menu selections.

- MENU : Press to open a menu, exit a menu or return to a previous menu.
- ∇ / FUNCTION1 : Moves the cursor downwards and selects items.
It also confirms a menu item assigned to FUNCTION1.
- ∧ / FUNCTION2 : Moves the cursor upwards and selects items.
It also confirms a menu item assigned to FUNCTION2.
- ENTER / FUNCTION3 : Press to confirm a setting or to open a submenu.
It also confirms a menu item assigned to FUNCTION3.

- When the control lock is on, the key mark appears and FUNCTION does not operate.
- In 3D assist mode, the item of FUNCTION3 is forcefully fixed to the 2D image adjustment mode item (2D ADJUST).

5 Picture and volume adjusting knobs/lamps

Functions in 2D (image adjustment) mode

Knob1	PEAK[PEAKING] 0 - 30 (0) / PHASE 0 - 60 (30) R-GAIN / R-BIAS (page 32)
Knob2	CHROMA 0 - 60 (30) / F-IN-R (page 46) 0 - 30 (30) G-GAIN / G-BIAS (page 32)
Knob3	VOLUME 0 - 60 (0) / BRIGHT 0 - 60 (30) / B-GAIN / B-BIAS (page 32)
Knob4	CONT.[CONTRAST] 0 - 60 (50) / B.LIGHT[BACKLIGHT] 0 - 100 (80)

() denotes factory preset values.

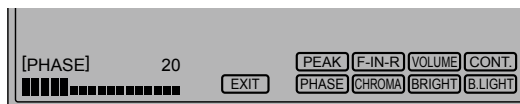

(Continued on next page)

Controls and Their Functions (continued)

Functions in 3D assist mode

Knob1	MIRROR (MIRROR) / HORIZONTAL (SHIFT) / MODE (CONVERGENCE) / SIZE (COLOR) / ZOOM (ZOOM FOCUS) / EXPAND (VERTICAL) / OVERLAY (OVERLAY)
Knob2	VERTICAL (SHIFT) / MANUAL (CONVERGENCE) / FOCUS-IN-RED (ZOOM FOCUS) / MARKER1 (VERTICAL) / MARKER (OVERLAY)
Knob3	SPEED (CONVERGENCE) / MARKER2 (VERTICAL)
Knob4	ASSIST FUNCTION (All Functions)

() : Selected assist function

- These are rotary push knobs. You can press one of the four knobs to display the corresponding assigned function and image adjusting knob status, and then make adjustments.
- The setting value is saved and the indication disappears when you press [ENTER] or when 10 seconds elapses after the setting value is changed.
- If you want to change the function assigned to a knob, press the knob and change the function. The selected function is displayed in green.
- When values are changed from the factory defaults, the LED above the knob (amber) lights.
- Settings are loaded when the monitor is turned on. However, operating changes cannot be made in the following conditions.
 - When the control lock is on, the key mark appears and setting values cannot be changed (page 51).
 - When the MONO function is ON (page 31), [PHASE] and [CHROMA] operations are disabled.
 - F-IN-R is enabled during operation of the FOCUS-IN-RED function.
 - While operating HV DELAY (page 41) (when set to any other setting than OFF), [BRIGHT] operation is disabled.
 - The "CONTRAST" and "BACK LIGHT" operations are disabled in BLACK MODE.

* For the operating procedures of adjusting knobs in 3D assist mode, refer to "3D Assist Mode" (page 52).

6 Tally Lamps (Red and Green)

Can be lit by a control signal (red tally and green tally) from a GPI/camera.

If the red tally and green tally light at the same time, the tally color will become amber.

7 Protection Panel

This panel is for protecting the liquid crystal.

- The protection panel can be removed by removing the four screws. When attaching the panel, note that there is no distinction between the back and front and the top and bottom.

8 Tilt Stand

The tilt stand allows you tilt the unit 15° forward or 20° backward.

When tilting the unit, firmly hold the bottom of the stand and move the top of the unit.

If you want to remove the tilt stand, refer to "How to Remove the Tilt Stand" on page 17.

<Note>

When tilting the monitor, be careful not to trap a hand between the monitor and stand.

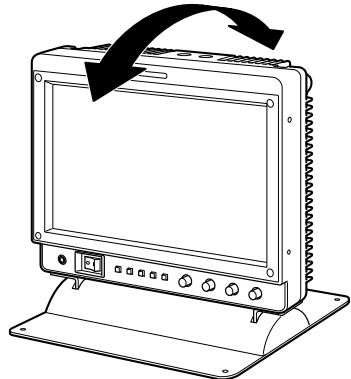

Rear panel

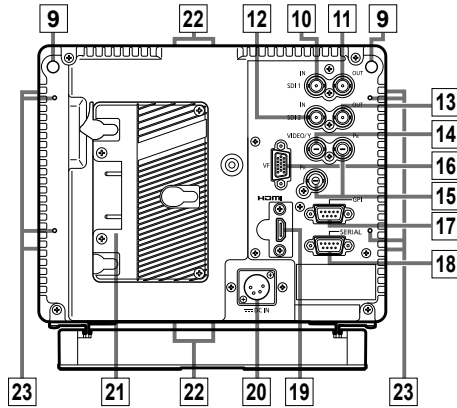

- 9 REAR TALLYS (red)**
Can be lit by a control signal from a GPI/camera.
- 10 SDI1 (HD/SD) input terminal (BNC)**
This is the SDI1 input terminal. (Compatible with HD/SD automatic switching, Compatible with 3G-SDI)
When you use 3D assist mode (page 51), input images for the left eye (L).
- 11 SDI1 active through output terminal**
This terminal outputs SDI1 input as is.
- 12 SDI2 (HD/SD) input terminal (BNC)**
This is the SDI2 input terminal. (Compatible with HD/SD automatic switching)
When you use 3D assist mode (page 51), input images for the right eye (R).
- 13 SDI2 active through output terminal**
This terminal outputs SDI2 input as is.
- 14 VIDEO/Y input terminal (BNC)**
This is the VIDEO signal (component signal) input terminal/Y signal (analog component signal) input terminal.
- 15 P_B/P_R input terminal (BNC)**
This is the P_B/P_R signal (analog component signal) input terminal.
- 16 VF terminal (D-SUB, 15 pins)**
This terminal connects to the VF (viewfinder) terminal of broadcasting and business cameras made by Panasonic.
The unit can be used as the viewfinder for such a camera.
- 17 GPI input terminal (D-SUB, 9 pins)**
External control is possible by using a GPI signal.
- 18 SERIAL terminal (D-SUB, 9 pins)**
External control is possible by using an RS-232C interface.
- 19 HDMI input terminal**
This is the HDMI input terminal.
- 20 DC IN terminal (XLR, 4 pins)**
This is the external DC power supply input terminal.
When a DC power supply is connected concurrently with the battery, the external power input takes precedence.
- 21 Battery holder**
This holder is used with a battery made by Anton/Bauer. (page 14)
- 22 Screw holes for fixing tripod**
There are two screw holes on both the top and bottom for fixing the unit to a tripod (compatible with 3/8-16UNC). A removable adapter is installed in one of the screw holes on the top of the unit, and enables a 1/4-20UNC screw to fit in the screw hole. Decide whether to use the adapter depending on the diameter of the tripod's fixing screw. Use a flat-blade screwdriver to remove or install the adapter.
- 23 Screw holes for multi-purpose fixing**
There are four screw holes (M3) for multi-purpose fixing on the rear of the unit, and two on each the left and right.

Supplying the power

An Anton/Bauer battery pack or V-mount type battery pack and external DC power supply can be used to power this unit.

Using an Anton/Bauer battery

■ Batteries for which connection verified

- HYTRON 50
- DIONIC 90
- DIONIC HC

1. Install the Anton/Bauer battery pack.

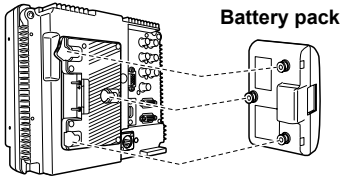

2. Insert the battery pack and slide it in the direction of the arrow.

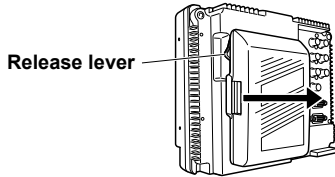

<Reference> To remove the battery pack

Slide it in the opposite direction to the one in which it was attached while keeping the release lever on the battery holder pulled down all the way.

Using a V-mount type battery

■ Batteries for which connection verified

- ENDURA E-7S
- ENDURA E-HL9
- ENDURA E-10

1. Install the V-mount type adapter plate.

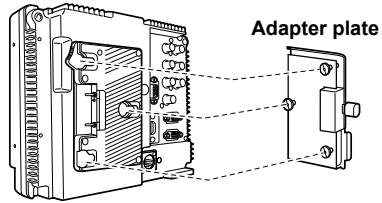

2. Insert the battery pack and slide it in the direction of the arrow.

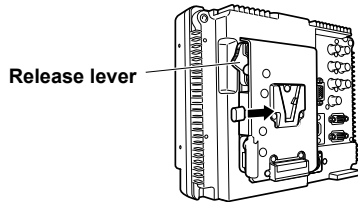

<Reference> To remove the adapter plate

Slide it in the opposite direction to the one in which it was attached while keeping the release lever on the adapter plate pulled down all the way.

<Notes>

- For details on the V-mount type adapter plate, contact the place of purchase.
- When you use a V-mount type adapter plate, the % (percent) indication cannot be displayed even if you use a battery with a battery level display function.
- For details on how to attach the V-mount type battery, see the instruction manual supplied with the battery holder.

Supplying the power (continued)

Using an external DC power supply

1. Connect the external DC power supply to the DC IN socket on this unit.

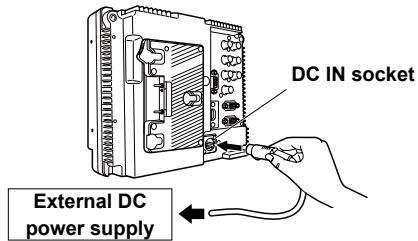

2. Turn "ON" the external DC power supply switch. (Where the external DC power supply has a power switch)
3. Turn "ON" the POWER switch on this unit.

If an external DC power supply is used, then check the ratings of the external DC power supply so that they are compatible with those of this unit.

Check the pin arrangements of the DC output terminal of the external DC power supply and those of the DC IN socket of this unit so that their polarities are correctly arranged. If +12 V are supplied to the unit's GND terminal by mistake, this may cause fire or injury.

The external DC power supply cannot be supplied from the DC output terminal of a Panasonic camera-recorder because the unit requires a current that exceeds the output rating of a Panasonic camera-recorder.

DC IN socket

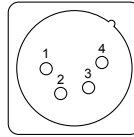

1: GND
4: +12 V

<Notes>

- Use a shield cable with a length of 2 m (6.56 feet) or less for the DC cord. Use of cords any longer than 2 m (6.56 feet) may result in noise appearing on the screen.
- If the battery pack and an external DC power supply are connected simultaneously, then the external DC power supply will have priority. If the external DC power supply is used, then the battery pack may be fitted or removed.
- If an external DC power supply is used, then make sure that the external DC power supply is first turned ON, then this unit is turned ON. If they are turned ON in the reverse order, then this unit may malfunction, because the output voltage of the external DC power supply will gradually increase.
- Input voltage that above the specification is not displayed accurately.

VF Function

The unit can be connected to broadcasting and business cameras made by Panasonic and used as a VF (viewfinder). If you want to use the unit as a VF (viewfinder), remove the tilt stand (page 17).

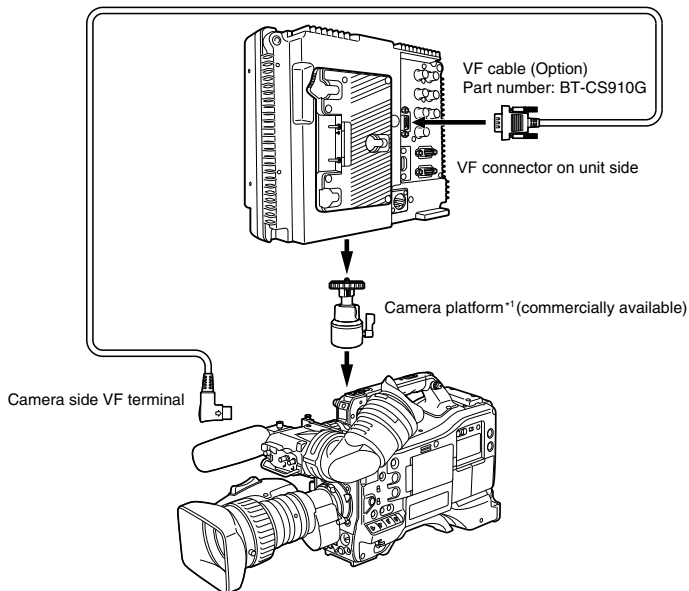

*1 Use a camera platform that can fully withstand the weight of the unit (1.7 kg (3.75 lb)).

<Note>

This unit requires a current that exceeds the output rating of a Panasonic camera-recorder, so the external DC power cannot be supplied from the DC output terminal of a Panasonic camera-recorder.

Do not use the battery pack. If this unit is mounted on the camera-recorder with the battery pack attached, the camera platform may be damaged. Use an external DC power supply.

Contact your vendor for details of broadcasting and business camera-recorders that will be launched in the future.

■ Panasonic camera-recorders that allow the unit to be connected as a VF(viewfinder)

Panasonic Camera-recorder	VF Video Signals*1		VF Communication				
			Monitor → Camera	Camera → Monitor*2			
	Y _P P _R	VIDEO	ZEBRA*3	TALLY		Indication of Abnormal Operating State	Changing of Aspect (SD Mode Only)
			RED*4	GREEN			
AJ-HPX3100G	✓		✓	✓	✓	✓	✓
AJ-HPX3700G	✓		✓	✓	✓	✓	
AJ-HPX2700G	✓		✓	✓	✓	✓	
AJ-HPX2000/2100	✓		✓	✓	✓	✓	✓
AJ-HDX900	✓		✓	✓	✓	✓	
AG-HPX500/502 (Monochrome images of SD resolution)	✓		✓	✓		✓	✓

*1 Configure the menu settings in accordance with the output signal format of the camera (page 48).

*2 For the settings, refer to the instruction manual of the camera.

*3 The ZEBRA information can be set for the camera (page 37).

*4 The tally lamp on the rear of the monitor lights in accordance with the REAR TALLY setting (page 37).

How to Remove the Tilt Stand

When you do not want to use the tilt stand such as when using the unit as a VF (viewfinder), remove the tilt stand mounting screw (four screws) with a Phillips driver and then remove the tilt stand from the unit.

When attaching the tilt stand, make sure to align the protrusions for alignment with the corresponding alignment holes.

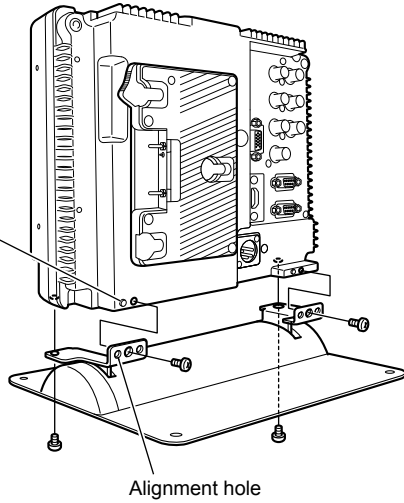

<Notes>

- When tilting the monitor, be careful not to trap a hand between the monitor and stand.
- When not using the tilt stand, take care that the unit does not fall over.
- When the unit will be permanently installed in one place, we recommend securing it in place using the screw holes at the bottom of the stand.

On-screen Display

The screen shows information such as the operating status display, picture adjusting knob status, sharpness display, function display, audio level meter display, time code display, closed caption display, DC power supply voltage and battery level display, and menu display.

Operating status display

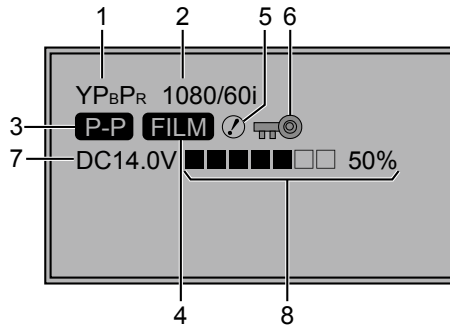

1. The selected input line (page 10)

- SDI1, SDI2, HDMI, VIDEO, YP_BP_R, VF-YP_BP_R/VF-VIDEO, INT SG.

2. Signal format

- “UNSUPPORT SIGNAL” appears if an unsupported signal is input. It may also indicate that the format selected in the “INPUT SELECT” menu does not match the input signal.
- “NO SIGNAL” appears without input signal.

3. Various indications (PIXEL TO PIXEL mode)

- This indicates the PIXEL TO PIXEL mode is engaged.

4. Various indications (FILM mode)

- This indicates that “GAMMA SELECT” of the “VIDEO CONFIG” is set to “FILM.”

5. Various indications (warning of improper operation status for the camera settings)

- This indicates there is an improper operation status relative to the camera settings.
- The condition to display differs depending on the type and settings of the camera used in combination with the unit. For details, see the instruction manual of the camera.

6. Various displays (lock setting)

- This indicates that the front operations lock is on. (page 51)

7. DC power supply voltage display

- DC power supply voltage is displayed.

8. Battery level display

- When you are using an Anton/Bauer battery with a battery level display function, the battery level is indicated by the number of ■ and a percentage. When you are using a battery other than that or the AC adapter, the display may not be shown or the battery level may not be indicated correctly. The battery level is indicated by a numerical value in 5 % increments. Also, there are seven ■ segments to indicate the battery level, and all seven of them are displayed until the battery level is approximately 70 %. After that, the number of ■ is reduced by one for each 10 % reduction in battery power and no marks are displayed when the battery level falls below approximately 10 %.
- The indication can be turned ON/OFF in “BATTERY REMAIN” of the “SYSTEM CONFIG” menu (page 34).

<Notes>

- The display state of the status can be set in “STATUS DISPLAY” of the “SYSTEM CONFIG” menu (page 34).
- “UNSUPPORT SIGNAL” and “NO SIGNAL” may not be properly displayed.
- For details on the operation status display in 3D Assist mode, refer to “3D Assist Mode” (page 52).

On-screen Display (continued)

Picture and volume adjusting knobs status display

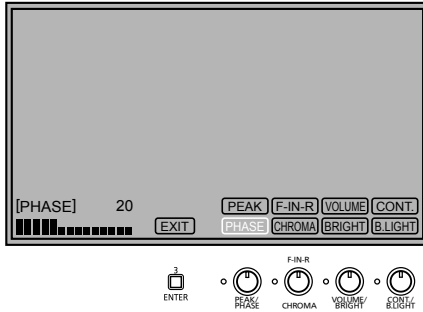

Picture adjusting knob (page 11)

- These are rotary push knobs.
- If you press a knob, the setting value state appears at the bottom left, and the item assigned to the corresponding knob is displayed at the bottom right.
- If multiple items are assigned to one knob, you can press the knob to switch items.
- The indication disappears when you press [ENTER] or after 10 seconds of inaction.
- Only adjustments that appear on the screen can be adjusted.

Status display:

The status of an item can be identified by the display color of the item name (page 11, "Picture and volume adjusting knobs").

White: An item not target for adjustment.

Green: An item target for adjustment.

Gray: An item which cannot be adjusted.

Sharpness display

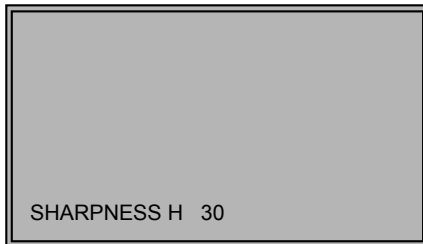

- Indicates the "SHARPNESS H/V" setting value of the "VIDEO CONFIG" menu.
- If no operation is performed for 2 minutes, the setting value is confirmed and the display disappears.

Function display

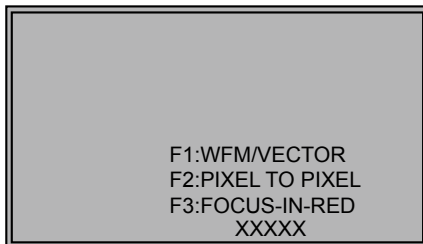

- Use the menu to open and set up functions.
- When "FUNCTION DISPLAY" (page 39) is set to ON1 or ON2, press any of the "FUNCTION1" to "FUNCTION3" buttons to display the functions assigned to the FUNCTION buttons.
- In 3D assist mode (page 52), [FUNCTION3] becomes the 2D picture quality adjustment mode button.
- If no operation is performed for 2 seconds, the setting value is confirmed and the display disappears.
- "XXXXX" indicates operating status (page 41, "Functions displayed during FUNCTION button operation").

On-screen Display (continued)

Audio level meter display

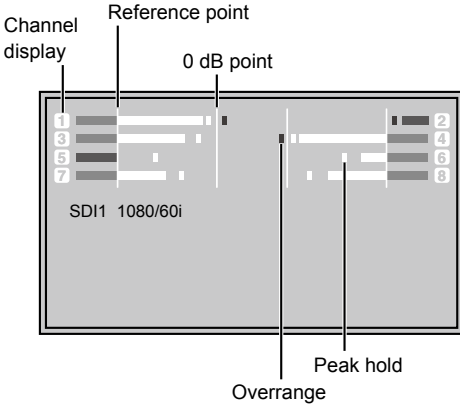

- A color skeleton bar meter indicates the audio level for SDI signals and HDMI signals.
- The display method of the audio level meter can be set in the menu (page 49).
- In 3D assist mode, the audio of the SDI1 (L) side is indicated.

Display color

- Green: Up to reference point (included)
- Yellow: Reference point (not included) to 0 dB point
- Red: Overrange

Time code (TC) display

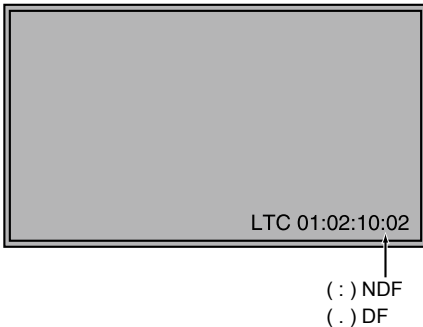

- Use the menu to display the time code for HD-SDI signal input. It also allows you to switch display mode (VITC, LTC, VUB, LUB). (page 50)

In VITC and LTC display mode:

- Displays the time code in hours: minutes: seconds: or frames.
- In drop-frame mode, a different delimiter between seconds and frames is used.

Note :

Read errors are displayed as "--:--:--:--"

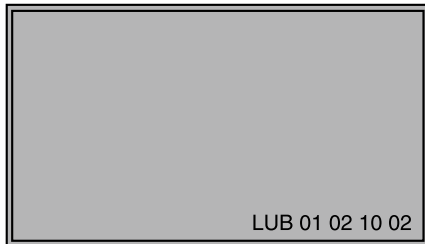

In VUB and LUB display modes:

- BG8, BG7, BG6, BG5, BG4, BG3, BG2, BG1 appear in the stated order.
BG: binary group
- The (:) delimiter does not appear.

Note :

Read errors are displayed as "--:--:--:--"

On-screen Display (continued)

Closed caption (CC) display

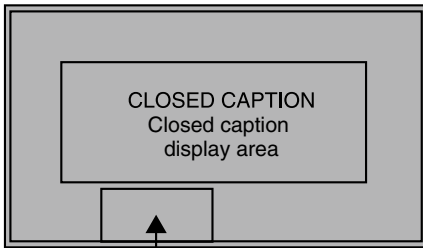
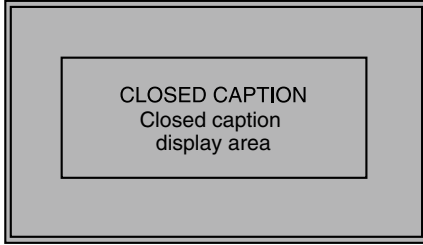

(When the specified window extends out of the entire screen)

- CLOSED CAPTION can be displayed when SDI signals and VIDEO signals are input.
- CLOSED CAPTION complies with the following standards.
 - Composite Standard EIA/CEA-608 (VBI)
 - SD-SDI CC Standard EIA-608 (ANC)
 - HD-SDI CC Standard EIA-708
- In the case of EIA-708, display is possible at a position simultaneously specified for multiple windows (up to 8).
- The display position is within a display area that is located inside the entire screen. (Refer to the following notes.)
- The display settings can be configured in the menus. You can also select the type of CLOSED CAPTION, display channel (EIA/CEA-608), and display service (EIA/CEA-708) in the menus. (page 50)

Notes:

- The specified window position is displayed as a position within the display area depending on the CLOSED CAPTION information.
- The window may extend out of the display area depending on the specified window position and size. In such a case, the window will be displayed but if the window also extends out of the entire screen, the display position of the window will be changed so that the window is displayed inside the entire screen.

DC power supply voltage and battery level display

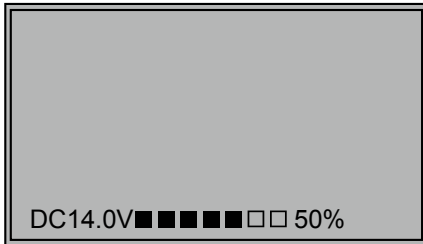

- DC power supply voltage is displayed.
- The battery level display is displayed when the battery you are using is an Anton/Bauer battery with a battery level display function.
- Displayed when the operating status display is not displayed.
- The display can be set in the menus. (page 34)

Notes:

- The DC power voltage and battery level serve as a near end warning indication as they flash when the level falls to the value set in the menu or lower. Furthermore, when the level drops to less than approximately 10.0 V, the "END BATTERY" battery level error is displayed in red, and the unit performs the shutdown process after approximately 3 seconds have elapsed.
- With some batteries, operation may be stopped by an over discharge function of the battery itself before the battery level error of the unit is displayed. We recommend replacing the battery as soon as possible.

How to Use the On Screen Menu

Menu display

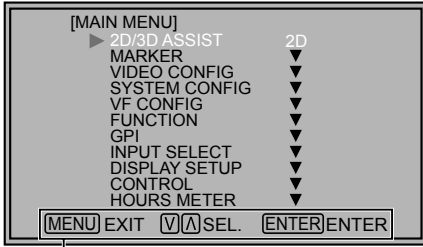

Displays the operation explanation for the menu button.

- This is the menu display.
- The menu display disappears after 2 minutes of inaction. (The setting values that were displayed at the time that the menu display disappeared are applied.)

Menu operations

1. Press [MENU] to display the MAIN menu.

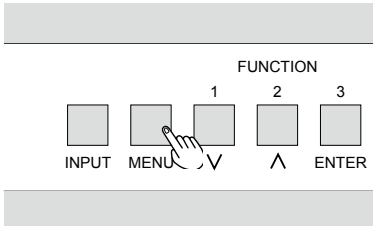

2. Press [V][^] to select a menu and press [ENTER].

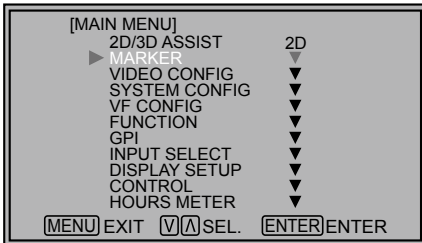

3. Press [V][^] to select a sub menu and press [ENTER].

The settings in the sub menu change to green.

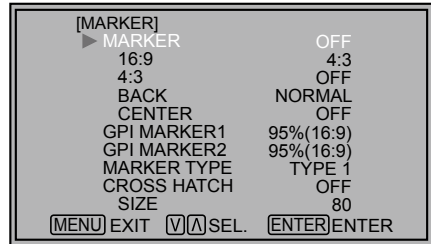

4. Press [V][^] to select a setting, then press [ENTER].

To cancel, press [MENU].

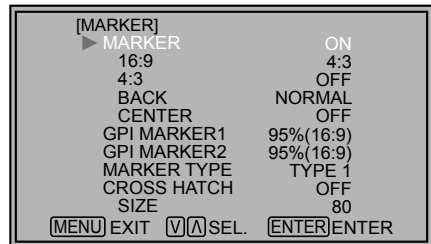

5. To return to the previous screen, press [MENU].

User Data

You can save and load up to five combinations of menu settings and adjustments made with the picture adjustment knob as user data. You can also return settings and adjustments to their factory defaults. User data include the following settings.

- Menu settings except “SETUP LOAD/SAVE” and “REMOTE in CONTROL” (including button function settings on the monitor front panel)
- Screen adjustments made with the picture adjusting knob

Saving user data

1. Press [MENU] to display the MAIN menu.
2. Press [V][^] to select the “SYSTEM CONFIG” menu and press [ENTER].
3. Press [V][^] to select the “SETUP SAVE” sub menu and press [ENTER].

The setting in the sub menu changes to green.

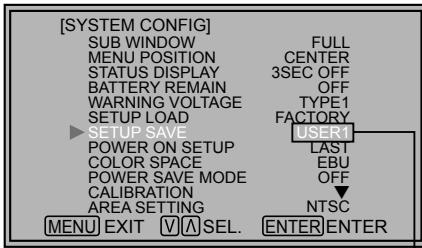

Changes to green

4. Press [V][^] to select a “USER1” to “USER5” file to save the settings to and press [ENTER].

The following screen appears.

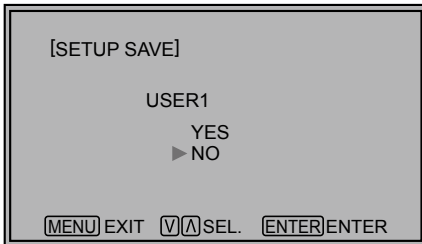

5. Select “YES”, and press [ENTER].

This saves the user data.

6. To return to the previous screen, press [MENU].

Loading user data

1. Press [MENU] to display the MAIN menu.
2. Press [V][^] to select the “SYSTEM CONFIG” menu and press [ENTER].
3. Press [V][^] to select the “SETUP LOAD” sub menu and press [ENTER].

The setting in the sub menu changes to green.

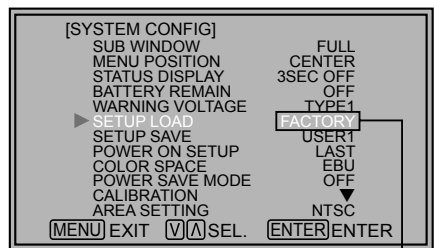

Changes to green

4. Press [V][^] to select a “USER1” to “USER5” file to load and press [ENTER].

The following screen appears.

- To return to the factory defaults, select “FACTORY.”

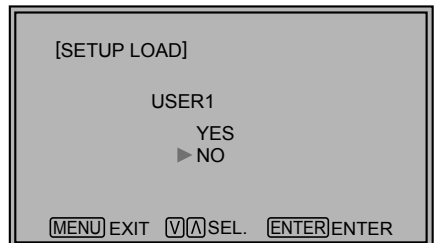

5. Select “YES”, and press [ENTER].

This loads the user data.

6. To return to the previous screen, press [MENU].

Main Menu

Menu configuration

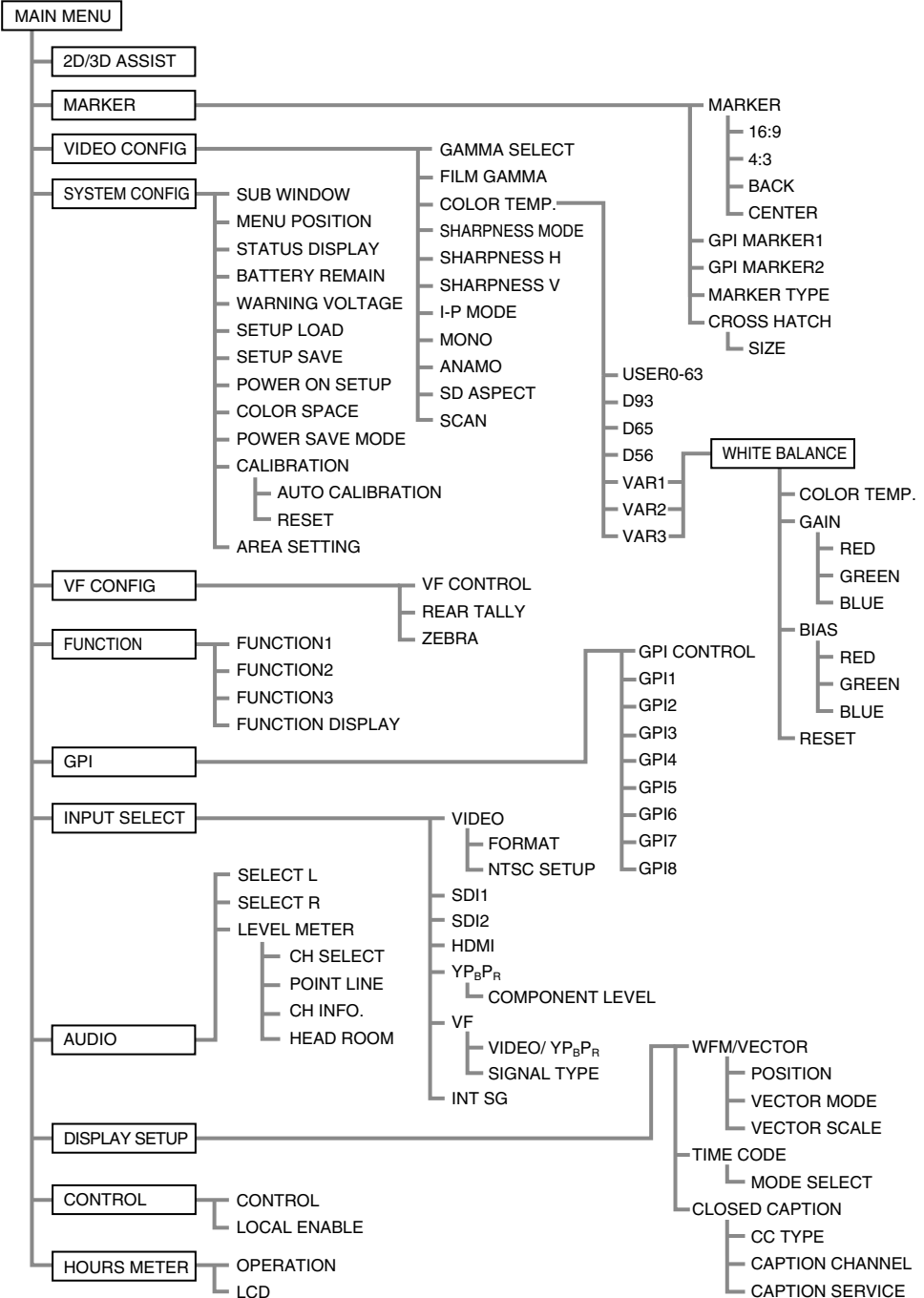

Main Menu (continued)

2D/3D ASSIST

The underlined values are factory preset setting values.

Setting	Description
<u>2D</u> 3D ASSIST	Switches between 2D mode and 3D assist mode. <2D> Operates in 2D mode. <3D ASSIST> Operates in 3D assist mode. If you switch to 3D assist mode, the channel setting is forcefully switched to SD11 (SDI2). Use knob 4 to switch between each of the assist functions. (page 52)

MARKER

The underlined values are factory preset setting values.

Sub menu	Settings	Description
MARKER	<u>OFF</u> *1 ON	Enables the MARKER setting.
<u>16:9</u> *2*3	OFF <u>4:3</u> 13:9 14:9 CNSCO 2.39 CNSCO 2.35 2:1 VISTA 95% 93% 90% 88% 80% USER 85%	Selects/displays the marker type for when the angle of view of the displayed image is 16:9. <OFF> No marker display <4:3> 4:3 marker <13:9> 13:9 marker <14:9> 14:9 marker <CNSCO 2.39> 2.39:1 marker <CNSCO 2.35> 2.35:1 marker <2:1> 2:1 marker <VISTA> VISTA marker <95%> 95 % area marker <90%> 90 % area marker <80%> 80 % area marker <93%> 93.1 % area marker (TYPE1) 93 % area marker (TYPE2) <88%> 89.5 % area marker (TYPE1) 88 % area marker (TYPE2) <USER> Area marker that is adjustable in 1 % increments within a range of 80 % to 100 %. However, when MARKER TYPE is TYPE1, 88 % becomes the aspect ratio of the vertical 89 %. (The factory preset setting value is 85 %.)

(Continued on next page)

*1 This setting is turned "ON" when receiving marker control in REMOTE operation. (GPI, if set, has priority.)

*2 These settings are disabled when the GPI function (page 62) is used to control the marker setting.

*3 These settings are enabled when the SD aspect setting for an HD signal and SD signal is 16:9 ("SD ASPECT" on page 31).

Main Menu (continued)

Sub menu	Settings	Description
4:3 *2*4	<u>OFF</u> 95% 93% 90% 88% 80% USER 85%	Selects/displays the marker type for when the angle of view of the displayed image is 4:3. <OFF> No marker display <95%> 95 % area marker <93%> 93 % area marker <90%> 90 % area marker <88%> 89 % area marker (TYPE1) 88 % area marker (TYPE2) <80%> 80 % area marker <USER> Area marker that is adjustable in 1 % increments within a range of 80 % to 100 %. However, when MARKER TYPE is TYPE1, 93 % becomes the aspect ratio of the vertical 93.1 %, and 88 % the aspect ratio of the vertical 89 %. (The factory preset setting value is 85 %.)
BACK *2	<u>NORMAL</u> HALF BLACK	Selects the background brightness around the marker. <NORMAL> Normal background <HALF> 50 % background brightness <BLACK> 0 % background brightness (black)
CENTER *2	<u>OFF</u> ON	Displays the center marker. <OFF> Turns the display off <ON> Turns the display on

(Continued on next page)

*2 These settings are disabled when the GPI function (page 62) is used to control the marker setting.

*4 These settings are enabled when the SD aspect setting for an SD signal is 4:3 (→ "SD ASPECT" on page 31).

Main Menu (continued)

Sub menu	Settings	Description
GPI MARKER1 *5	4:3 13:9 14:9 CNSCO 2.39 CNSCO 2.35	GPI MARKER1 : Selects the marker displayed by the GPI terminal "MARKER1 ON/OFF" (page 62) operation. GPI MARKER2 : Selects the marker displayed by the GPI terminal "MARKER2 ON/OFF" (page 62) operation.
GPI MARKER2 *5	2:1 VISTA <u>95% (16:9)</u> 93% (16:9) 90% (16:9) 88% (16:9) 80% (16:9) USER(16:9) 95% (4:3) 93% (4:3) 90% (4:3) 88% (4:3) 80% (4:3) USER(4:3)	<4:3> 4:3 marker <13:9> 13:9 marker <14:9> 14:9 marker <CNSCO 2.39> 2.39:1 marker <CNSCO 2.35> 2.35:1 marker <2:1> 2:1 marker <VISTA> VISTA marker <95% (16:9) > 95% area marker for 16:9 aspect ratio <93% (16:9) > 93% area marker for 16:9 aspect ratio <90% (16:9) > 90% area marker for 16:9 aspect ratio <88% (16:9) > 88% area marker for 16:9 aspect ratio <80% (16:9) > 80% area marker for 16:9 aspect ratio <USER (16:9) > User settings area marker for 16:9 aspect ratio <95% (4:3) > 95% area marker for 4:3 aspect ratio <93% (4:3) > 93% area marker for 4:3 aspect ratio <90% (4:3) > 90% area marker for 4:3 aspect ratio <88% (4:3) > 88% area marker for 4:3 aspect ratio <80% (4:3) > 80% area marker for 4:3 aspect ratio <USER (4:3) > User settings area marker for 4:3 aspect ratio
MARKER TYPE *6	TYPE1 TYPE2	Selects conventional monitor or camera recorder marker size. <TYPE1> Conventional monitor marker size <TYPE2> Marker size compliant with the camera recorder (Panasonic made)
CROSS HATCH	HIGH LOW <u>OFF</u>	Turns the cross hatch grid on and off and sets its density. <HIGH> Displays a bright cross hatch grid <LOW> Displays a dim cross hatch grid <OFF> Turns the display off
SIZE	<u>80</u> 40	Selects the cross hatch grid size. <80> 80 dots and 80 lines <40> 40 dots and 40 lines

*5 Remote control via RS-232C ends in error (error response: ER001) when "GPI MARKER1" or "GPI MARKER2" is selected with the GPI function.

*6 Display size for SD signals differ.

TYPE1: The effective horizontal area meets the SMPTE125M for NTSC and ITU-R BT. 601-5 for PAL.

TYPE2: The effective horizontal area meets the EIA-RS170A for NTSC and ITU-R BT. 470-4 for PAL.

<Notes>

- The marker is not displayed during 2-screen display (SUB WINDOW), PIXEL TO PIXEL mode, and 3D assist mode.
- The marker is not displayed during VF line operation.

Main Menu (continued)

Types of MARKER

■ 16:9 marker

(Displayed when using HD, or when using SD with a 16:9 aspect ratio)

The marker is only displayed as a vertical bar. In addition, the  section becomes the "MARKER BACK" item.



4:3 marker

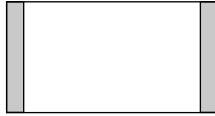

13:9 marker



14:9 marker

VISTA marker, 2:1 marker, CNSCO marker

A horizontal dotted line is displayed as the marker.



VISTA marker

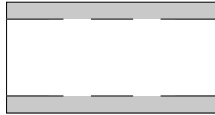

2:1 marker

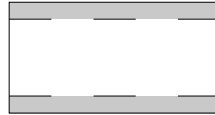

CNSCO marker
(2.35/2.39)

The marker is displayed as a vertical dotted line when "UNDER" is selected under "SCAN" in the "VIDEO CONFIG" menu.



VISTA marker



2:1 marker



CNSCO marker
(2.35/2.39)

Area marker

A dotted line is displayed as the marker.



95 % Area marker

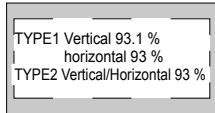

93 % Area marker

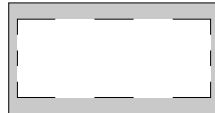

90 % Area marker

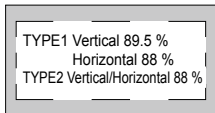

88 % Area marker



80 % Area marker

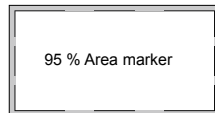

USER Area marker *1

*1 You can adjust the value within the range of 80 % to 100 % in increments of 1 % by pressing [V][^].

(Continued on next page)

Main Menu (continued)

■ 4:3 marker

(Displayed for SD input in 4:3 aspect ratio mode)

This marker is displayed as a dotted line.

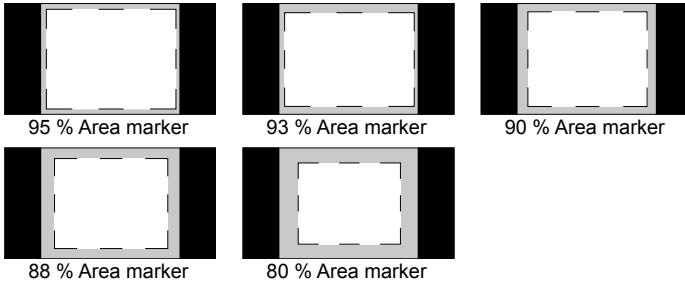

(Displayed for HD input and SD input in 16:9 ratio mode.)

This marker is displayed as a dotted line.

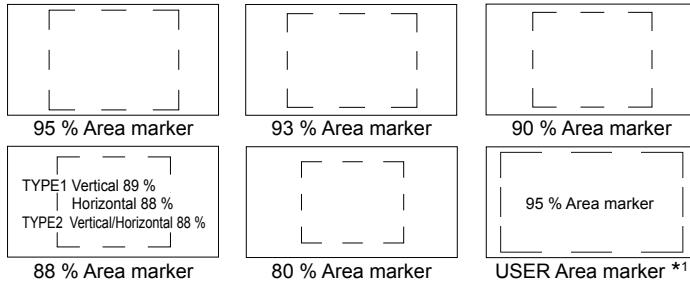

*1 You can adjust the value within the range of 80 % to 100 % in increments of 1 % by pressing [V][^].

You can display the 4:3 marker and the 16:9 marker simultaneously.

Simultaneous display example

The  section becomes the "MARKER BACK".

It controls the background of the marker selected with a 16:9 ratio.

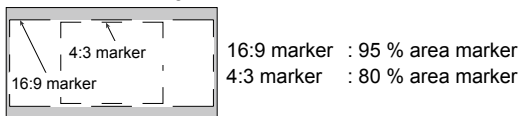

■ Center marker

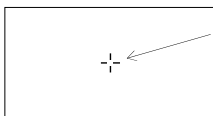

Center marker

This marker is displayed at the center of the screen.

Main Menu (continued)

VIDEO CONFIG

The underlined values are factory preset setting values.

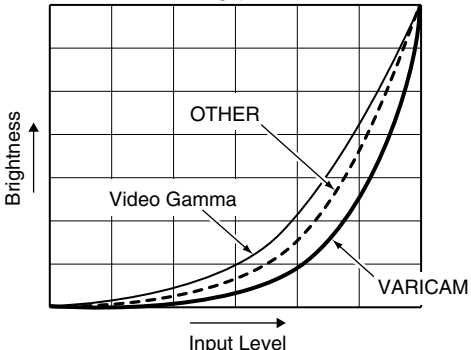
Sub menu	Settings	Description
GAMMA SELECT *1	STANDARD FILM <u>STUDIO/PST</u>	<p>Selects gamma curve.</p> <p><STANDARD> Standard mode <FILM> Film mode <STUDIO/PST> Color emphasis mode (a mode that approximates CRT display capability suitable for studio or postproduction application)</p> <p>When FILM is selected, the FILM mark is displayed for the operating status.</p>
FILM GAMMA	<u>VARICAM</u> OTHER	<p>Selects type of FILM gamma mode.</p> <p><VARICAM> For VARICAM use <OTHER> Other</p> <p>(Gamma curve image)</p>  <p>The graph shows three curves on a grid. The vertical axis is labeled 'Brightness' and the horizontal axis is labeled 'Input Level'. A solid line represents 'Video Gamma', a dashed line represents 'OTHER', and a solid line represents 'VARICAM'. The VARICAM curve is the steepest, followed by Video Gamma, and then OTHER.</p>
COLOR TEMP.	USER 0 - 63 *2 D93 <u>D65</u> D56 VAR1 VAR2 VAR3	<p>Selects color temperature.</p> <p><USER 0 - 63> Adjustable settings 0 - 63 (equivalent to a color temperature range of 3,000 K - 9,300 K)</p> <p><D93> Equivalent to a color temperature of 9,300 K <D65> Equivalent to a color temperature of 6,500 K <D56> Equivalent to a color temperature of 5,600 K <VAR1> WB adjustment mode *3 <VAR2> WB adjustment mode *3 <VAR3> WB adjustment mode *3</p>

(Continued on next page)

*1 In split-screen display, changes are not reflected to the still image in the main window.

*2 When selecting USER 0 - 63

1) Push [ENTER] (USER changes to blue).

2) Select 0 - 63 with [V], [^] and push [ENTER].

*3 Selecting "VAR1", "VAR2" and "VAR3" engages the WB adjustment mode (page 32).

Main Menu (continued)

Sub menu	Settings	Description
SHARPNESS MODE *4	HIGH LOW	Selects the width of outline correction edge. <HIGH> Narrow edge <LOW> Wide edge
SHARPNESS H *4	0 - 30	Sets horizontal outline correction. The item display moves to the lower part of the screen during adjustment.
SHARPNESS V *4	0 - 30	Sets vertical outline correction. The item display moves to the lower part of the screen during adjustment.
I-P MODE *5	MODE2 <u>MODE1</u>	Selects IP conversion mode. (see "IP mode" below.) <MODE2> Intra-field interpolation <MODE1> Intra-frame interpolation
MONO	<u>OFF</u> ON	Switches between color and monochrome (MONO). <OFF> Color <ON> Monochrome * When ON, the CHROMA setting of the picture adjusting knob is fixed at 0.
ANAMO *6	<u>OFF</u> ON	With an Anamo lens and HD-SDI input, the picture is resized to Anamo magnification (the vertically enlarged signal can be vertically compressed and corrected for display).
SD ASPECT	<u>4:3</u> 16:9	Sets the aspect ratio for SD signal input. <4:3> 4:3 display <16:9> 16:9 display
SCAN *6	<u>NORMAL</u> UNDER	Sets under-scan and normal display. <NORMAL> Normal display <UNDER> Under-scan

- *4 The following sharpness values are available and the settings for the selected input signal is displayed. Adjustment status during selection appears at the bottom left of the screen.
- 1) VIDEO system input (VIDEO) (the factory defaults are SHARPNESS MODE: LOW and SHARPNESS H/V: 0)
 - 2) HD for any other input (the factory defaults are SHARPNESS MODE: HIGH and SHARPNESS H/V: 0).
 - 3) SD for any other input (the factory defaults are SHARPNESS MODE: LOW and SHARPNESS H/V: 0).
- *5 To use the "SUB WINDOW" (page 42) function,
- 1) Change settings after exiting the "SUB WINDOW" function.
 - 2) It is recommended to use "MODE2" for handling fast video.
- *6 "SCAN" changes are not reflected in Anamo size display.

IP mode

"MODE1" performs IP conversion using intra-frame interpolation.
This monitor suppresses the delay to within 1 field.
The factory default is "MODE1".

"MODE2" performs IP conversion using intra-field interpolation.
Since interpolation is performed inside each field, this mode is suitable for checking interlace status.

Main Menu (continued)

■ WB (WHITE BALANCE) adjustment mode

Select "VAR1" to "VAR3" for "COLOR TEMP." in the "VIDEO CONFIG" menu to make "WHITE BALANCE VAR1" to "WHITE BALANCE VAR3" (WB) adjustments.

The underlined values are factory preset setting values.

Sub menu	Settings	Description
COLOR TEMP.*1	USER 0 - 63 D93 <u>D65</u> D56	Selects the color temperature that will become the basis for adjustment. <USER 0 - 63> Adjustable settings 0 - 63 (equivalent to a color temperature range of 3,000 K - 9,300 K) <D93> Equivalent to a color temperature of 9,300 K <D65> Equivalent to a color temperature of 6,500 K <D56> Equivalent to a color temperature of 5,600 K
GAIN	▼	Adjusts the GAIN elements Press [ENTER] to switch to RGB direct adjustment mode. (This allows you to begin adjusting GAIN first.)
RED	0 - 1023 (Factory defaults are color temperature <D65> values.)	Adjusts the GAIN elements for RED. (For numerical value confirmation)
GREEN	*These are the adjustments made before shipment from the factory.	Adjusts the GAIN elements for GREEN. (For numerical value confirmation)
BLUE		Adjusts the GAIN elements for BLUE. (For numerical value confirmation)
BIAS	▼	Adjusts the BIAS elements [Press [ENTER] to switch to RGB direct adjustment mode. (This allows you to begin adjusting BIAS first.)
RED	- 512 - 511 (Factory default: 0)	Adjusts the BIAS elements for RED. (For numerical value confirmation)
GREEN		Adjusts the BIAS elements for GREEN. (For numerical value confirmation)
BLUE		Adjusts the BIAS elements for BLUE. (For numerical value confirmation)
RESET	▼	Resets "GAIN RED" - "BIAS BLUE" to color temperature values selected under "COLOR TEMP."

*1 Selecting "COLOR TEMP." and pressing [ENTER] after making a change, opens a confirmation screen. Selecting "YES" and pressing [ENTER] in this screen resets selected GAIN and BIAS values to the selected color temperature values.

Main Menu (continued)

■ GAIN/BIAS RGB direct adjustment mode

If you press [ENTER] when the [GAIN] or [BIAS] item is selected in the WHITE BALANCE VAR (1 to 3) menu, the screen switches to the one below and you can use the picture adjusting knobs to directly adjust the RGB while checking the picture.

R is assigned to knob 1, G to knob 2, and B to knob 3.

If "WHITE BALANCE" is assigned to FUNCTION1 to FUNCTION3, this mode can also be accessed from the FUNCTION buttons.

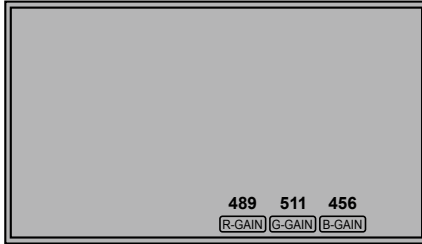

- You can switch between GAIN and BIAS by pressing the corresponding knob.
 - If you press [ENTER] in the [GAIN] menu, GAIN adjustment is displayed first.
 - If you press [ENTER] in the [BIAS] menu, BIAS adjustment is displayed first.
 - When you access the mode from a FUNCTION button, GAIN adjustment is displayed first.
- The adjustment item name and the numerical value of the element is displayed above each of the knobs.
- Press the [MENU] button to return to menu display. *1
- If you switched the mode with a FUNCTION button, display disappears if you press the FUNCTION button. *1

*1 The same operation is also performed after 10 seconds of inaction.

Main Menu (continued)

SYSTEM CONFIG

The underlined values are factory preset setting values.

Sub menu	Settings	Description
SUB WINDOW	<u>FULL</u> PART	Selects sub-window type. <FULL> Reduces the entire images for both input signals and places them side by side. <PART> Cuts out the center of the images for both input signals and places them side by side (the images are shown at their original size).
MENU POSITION	<u>CENTER</u> LB RB RT LT	Positions the on-screen menu. <CENTER> Center of the screen <LB> Left Bottom <RB> Right Bottom <RT> Right Top <LT> Left Top
STATUS DISPLAY *1	<u>CONTINUE</u> <u>3SEC OFF</u> OFF	Sets the display state of the operating status display (page 18). <CONTINUE> Displayed at all times <3SEC OFF> Displayed for 3 seconds after a status change.*2 <OFF> Not displayed.
BATTERY REMAIN	<u>OFF</u> ON	Selects whether DC power supply voltage and battery level display. <OFF> Not displayed. <ON> Displayed.
WARNING VOLTAGE *3	<u>TYPE1</u> TYPE2	Sets the near end warning voltage for the battery level display. <TYPE1> Select this when you will mainly use an external DC power supply. Near end is approximately 11.3 V. <TYPE2> Select this when you will mainly use a battery. Near end is approximately 13.3 V.
SETUP LOAD *3	USER5 *4 USER4 *4 USER3 *4 USER2 *4 USER1 *4 <u>FACTORY</u>	Loads saved factory defaults (FACTORY) or user data (USER1 - USER5) (page 23) . After loading user data, the screen displays the signal selected before user data was loaded.
SETUP SAVE	USER5 USER4 USER3 USER2 <u>USER1</u>	Up to 5 sets of user data can be saved (page 23). They save menu settings and adjustments made with the picture adjusting knob except "SETUP SAVE/SETUP LOAD."
POWER ON SETUP	USER5 USER4 USER3 USER2 USER1 FACTORY <u>LAST</u>	Selects the settings used when the power is turned on. <LAST> Starts in the mode used when the power was last turned off. <FACTORY> Starts up using the factory defaults. <USER1 - 5> Starts up using USER registered settings.

(Continued on next page)

*1 When PIXEL to PIXEL, operation is with CONTINUE regardless of the setting.

*2 When PIXEL TO PIXEL/3D assist mode, the 3SEC OFF setting becomes equivalent to CONTINUE.

*3 When the BATTERY REMAIN display setting is OFF, near end warning display does not occur.

*4 The settings of USER1 to USER 5 and FACTORY are the same at the time of shipment from the factory.

Main Menu (continued)

Sub menu	Settings	Description
COLOR SPACE * ⁵	<u>SMPTE-C</u> EBU ITU-709 * ⁶	Sets the studio standard color space.
POWER SAVE MODE	<u>OFF</u> ON	Sets the power save mode <ON> The backlight dims when no signal (NO SIGNAL) is input for 60 seconds or longer. Signal input or menu operation will return the backlight to its normal brightness.
CALIBRATION	▼	Connect Display Color Analyzer CA-210 and then perform calibration. This also allows you to restore the calibration data to the factory preset setting values. (pages 35, 36, and 37)
AREA SETTING	<u>NTSC</u> NTSC (J) PAL	Selects the area of the unit. (→ “Selecting Area of Use” on page 8) • The setting does not vary depending on the operation of SETUP LOAD or POWER ON SETUP.

*⁵ The factory preset setting value varies depending on the area set in “AREA SETTING”.

*⁶ ITU-709 indicates the ITU-R BT.709 standard.

■ CALIBRATION

The CALIBRATION function in this unit measures LCD panel characteristics from low to high brightness values and internal monitor processing handles CALIBRATION.

CALIBRATION does not rely on image quality settings since internal signals are used for a calibration. CALIBRATION in this unit is made at D65 color temperature and other color temperatures are results calculated automatically from this value.

■ Equipment required for calibration

- Konica Minolta CA-210 or CA-310 display color analyzer
- Konica Minolta CA-PU12 or CA-PU15 standard measurement probe
- A RS-232C cable (male to male, straight)

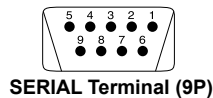

Connect the SERIAL terminal on this unit to the RS-232C terminal on the display color analyzer using a straight cable.

Analyzer Side (Straight)			This unit Side	
Pin number	Signal		Pin number	Signal
1	CD		1	N.C.
2	RXD	←	2	TXD
3	TXD	→	3	RXD
4	DTR	→	4	DSR
5	GND	—	5	GND
6	DSR	←	6	DTR
7	RTS	→	7	CTS
8	CTS	←	8	RTS
9	GND		9	N.C.

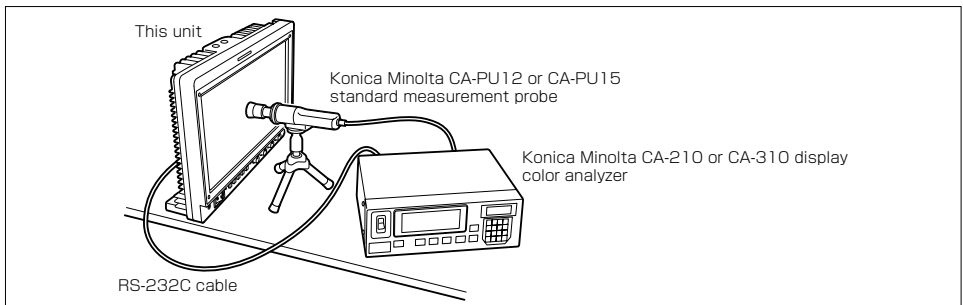

(Continued on next page)

Main Menu (continued)

- When using the CA-210 display color analyzer, be sure to set the compensation values shown on the right. If they are not set, correct calibration will not be performed. For details on setup procedures, refer to the CA-210 User's Guide.

Compensation	W	R	G	B
x	0.296	0.6534	0.2851	0.1485
y	0.3036	0.3271	0.5927	0.0523
Lv	203.4	43.18	148.1	15.5

- There is no compensation when using Display Color Analyzer CA-310.
- Turn on this unit and perform adequate aging (about 1 hour) before starting calibration.
- Make the room dark so that no external light can enter the standard measurement probe before starting the calibration. If external light enters the probe, the low brightness characteristics may not be calibrated correctly.
- LCD panel characteristics and instrument error in the display color analyzer may sometimes result in small differences in values after calibration.
In a fine tuning of the monitor, also set GAIN and BIAS for R, G and B in the COLOR TEMP. VAR mode.
- Do not apply the probe to a WFM/VECTOR display on the screen.

■ CALIBRATION

Select CALIBRATION in the "SYSTEM CONFIG" menu to open the following menus.

Sub menu	Settings	Description
AUTO CALIBRATION *1	▼	Connect a CA-210 Display color analyzer and use this submenu to make a calibration. Select "AUTO CALIBRATION" and select "YES" in the confirmation screen that appears to start calibration.
RESET *2	▼	Returns calibration data to their factory defaults. Select "RESET" and select "YES" in the confirmation screen that appears to return calibrated values to their factory defaults.

*1 "EXECUTING" is displayed during "AUTO CALIBRATION" and "COMPLETE" appears when calibration ends. "INCOMPLETE" appears if calibration could not be completed.

*2 When "RESET" ends, "COMPLETE" appears.

Performing AUTO CALIBRATION

- Press [V][^] in the "SYSTEM CONFIG" menu, select the [CALIBRATION] submenu and press [ENTER].
- Press [V][^], select the [AUTO CALIBRATION] submenu and press [ENTER].

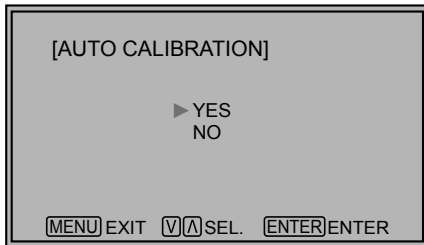

- Select "YES" and press [ENTER].

This starts calibration.

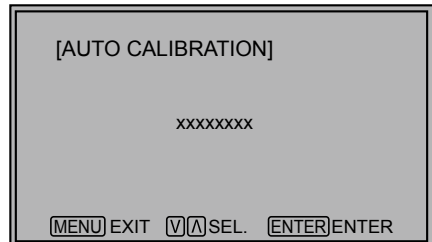

xxxxxxx indicates that one of the following messages with the meaning listed below appears.

EXECUTING: Operation in progress
 COMPLETE: Operation completed
 INCOMPLETE: Operation incompleted.
 (Check the SERIAL connection or display color analyzer connection.)

- Turn the power off and then on after performing auto calibration.

Main Menu (continued)

RESET operation

1. Press [V][^] in the “SYSTEM CONFIG” menu, select the [CALIBRATION] submenu and press [ENTER].
2. Press [V][^], select the [RESET] submenu and press [ENTER].

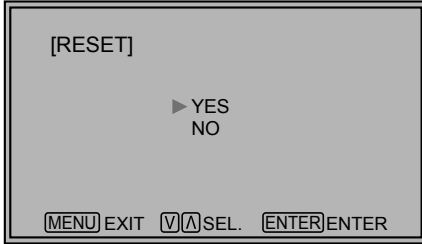

3. Select “YES” and press [ENTER].

This starts calibration.

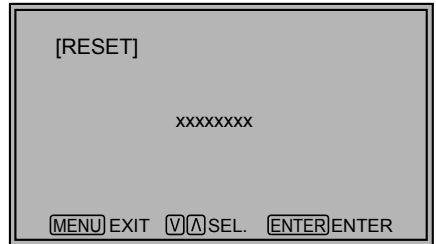

xxxxxxx indicates that the following message with the meaning listed below appears.

COMPLETE: Operation completed

4. Turn the power off and then on after performing auto calibration.

VF CONFIG

The underlined values are factory preset setting values.

Sub menu	Settings	Description
VF CONTROL	<u>VF-CH</u> ALL-CH	Used to select the input line for the VF function of the monitor. (VF function: tally lamps (red and green) lit, zebra displayed,  displayed, aspect changed [SD]) <VF-CH> Only enabled when the VF line is selected. <ALL-CH> Enabled with all input lines.
REAR TALLY	OFF <u>ON</u>	Used to allow control of the tally lamp on the rear of the monitor. <OFF> Does not light. <ON> Lights when TALLY control from a GPI/camera is ON.
ZEBRA	OFF <u>ON</u>	Used to set ZEBRA information in the camera. <OFF> Sets the information to OFF. <ON> Sets the information to ON.

- The priority sequence for GPI control and SERIAL is as follows: GPI > VF CONFIG > SERIAL.

Main Menu (continued)

FUNCTION

The underlined values are factory preset setting values.

Sub menu	Settings	Description
FUNCTION 1 - FUNCTION 3	HV DELAY BLUE ONLY GAMMA SELECT SD ASPECT SCAN SUB WINDOW WFM/VECTOR MARKER WHITE BALANCE PIXEL TO PIXEL PIXEL POSITION FOCUS-IN-RED ZEBRA REAR TALLY LEVEL METER CROSS HATCH MONO BLACK MODE TIME CODE CLOSED CAPTION UNDEF (Factory default: FUNCTION1: WFM/VECTOR FUNCTION2: PIXEL TO PIXEL FUNCTION3: FOCUS-IN-RED)	Selects functions to be assigned to [FUNCTION1] - [FUNCTION3] (front panel buttons). <HV DELAY> *1 Displays the image blanking period. The display changes in the following order. DELAY OFF → H DELAY → V DELAY → HV DELAY → DELAY OFF <BLUE ONLY> *1 Cuts the red and green signals. Use this function to check phase and chroma. This button toggles between ON and OFF. <GAMMA SELECT>*2*3 Displays the gamma curve. The display changes in the following order. GAMMA STANDARD → GAMMA FILM → GAMMA STDIO/PST → GAMMA STANDARD <SD ASPECT> *2 *3 Switches between "16:9" and "4:3." <SCAN> *2*3 Switches between "UNDER SCAN" and "NORMAL SCAN". <SUB WINDOW> *1 Sets the split-screen function. The display changes in the following order. SINGLE → FULL/PART → STILL → SINGLE <WFM/VECTOR> *2 Displays waveform or vector display. For details on the available operation items, refer to page 41. <MARKER> *2*3*4 Turns the marker on and off. For details on the available operation items, refer to page 41. <WHITE BALANCE> WHITE BALANCE GAIN/BIAS RGB direct adjustment can only be accessed when VAR1 to VAR3 are selected in COLOR TEMP. <PIXEL TO PIXEL> Turns the PIXEL TO PIXEL function On and Off. <PIXEL POSITION> Positions the display of signals in PIXEL TO PIXEL mode.

(Continued on next page)

*1 The settings are cancelled when the power is turned OFF.

*2 If these settings are changed, the menu settings will also change.

*3 The control settings do not operate during GPI operation.

*4 Not displayed when 16:9, 4:3 and CENTER are all OFF in the MARKER menu settings.

Main Menu (continued)

Sub menu	Settings	Description
(From the previous page)		<p><FOCUS-IN-RED>*3*5 Used to highlight in red the section of the image that is being focused.</p> <p><ZEBRA> Used to set the zebra display ON or OFF for the camera.</p> <p><REAR TALLY> *2*6 Used to set the rear tally ON or OFF.</p> <p><LEVEL METER> *2 Turns the AUDIO LEVEL METER display On and Off.</p> <p><CROSS HATCH> *2 Displays the cross hatch grid. The display changes in the following order. CROSS HATCH OFF → CROSS HATCH LOW → CROSS HATCH HIGH</p> <p><MONO> *2*3 Switches between color and monochrome.</p> <p><BLACK MODE> *1 *7 This mode is for reducing floating black and checking the gradation of dark sections. The brightness of the backlight is reduced and the contrast is increased so that up to 75 % of the input signal level has the same gamma curve as the set GAMMA SELECT. The signal level on or above that is clipped at 75 %.</p> <p><TIME CODE> *2 Turns the time code display on and off.</p> <p><CLOSED CAPTION> *2 Turns the closed caption display on and off. For details on the available operation items, refer to page 41.</p> <p><UNDEF> Undefined</p>
FUNCTION DISPLAY *8	OFF <u>ON1</u> ON2 *9	<p>Selects display of functions assigned to [FUNCTION1] - [FUNCTION3] (front panel buttons). It also selects button action (1- touch, 2-touch, off).</p> <p><OFF> No function display.</p> <p><ON1> 1-touch action to display and perform functions.</p> <p><ON2> 2-touch action to display and perform functions.</p>

• If a FUNCTION button is pushed during the picture adjusting knobs display, the picture adjusting knobs display will be cancelled and the FUNCTION operation cannot be executed.

*1 The settings are cancelled when the power is turned OFF.

*2 If these settings are changed, the menu settings will also change.

*3 The control settings do not operate during GPI operation.

*5 During FOCUS-IN-RED operation, the detection sensitivity can be changed with the F-IN-R knob. The setting range is from 0 to 30, with a higher numerical value resulting in higher detection sensitivity (the focus becomes worse).

*6 Only enabled when TALLY control from the camera or GPI (R-TALLY) is ON.

*7 The bright picture more than 75 % is clipped. The back light and contrast cannot be adjusted.

*8 The operating status is displayed regardless of the ON/OFF setting.

*9 The function displayed with the ON2 setting can be operated with a button only during the time that it is displayed.

Main Menu (continued)

■ FUNCTION setting restrictions

Under the following conditions, "INVALID FUNCTION" is displayed and the settings cannot be configured.

Settings	Inoperable Condition or Mode
HV DELAY	<ul style="list-style-type: none"> • SUB WINDOW • WFM • PIXEL TO PIXEL • 3D ASSIST • When HDMI (640 x 480) input
GAMMA SELECT	<ul style="list-style-type: none"> • When GPI is set • When HDMI (640 x 480) input
SD ASPECT	<ul style="list-style-type: none"> • When GPI is set • SUB WINDOW (Still image) • 3D ASSIST • When HDMI (640 x 480) input
SCAN	<ul style="list-style-type: none"> • When GPI is set • SUB WINDOW • PIXEL TO PIXEL • 3D ASSIST • When HDMI (640 x 480) input
SUB WINDOW	<ul style="list-style-type: none"> • 3D ASSIST • When HDMI (640 x 480) input
WFM/VECTOR	(VECTOR is not displayed when other than SDI1 or SDI2 input) <ul style="list-style-type: none"> • SUB WINDOW • PIXEL TO PIXEL • 3D ASSIST • When HDMI (640 x 480) input
MARKER	<ul style="list-style-type: none"> • When GPI is set • SUB WINDOW • 3D ASSIST • When HDMI (640 x 480) input
WHITE BALANCE	When other than VAR1 to VAR3 selected in COLOR TEMP.
PIXEL TO PIXEL	(Enabled when 1080i/p signal input) <ul style="list-style-type: none"> • When other than 1080i/p signal input • SUB WINDOW • 3D ASSIST
FOCUS-IN-RED	<ul style="list-style-type: none"> • When WFM is ON • When GPI is set • When INT-SG is selected
LEVEL METER	When other than SDI1, SDI2, or HDMI input
MONO	<ul style="list-style-type: none"> • When GPI is set • When HDMI (640 x 480) input
TIMECODE	When other than HD-SDI input
CLOSED CAPTION	<ul style="list-style-type: none"> • When HDMI (640 x 480) input • When VF signal input • When YP_BP_R signal input • 3D ASSIST

- The function assigned to FUNCTION3 does not work when you operate the unit in 3D assist mode because the FUNCTION3 button becomes specifically for switching to 2D picture adjustment mode (2D ADJUST).

Main Menu (continued)

■ Functions displayed during FUNCTION button operation

Pressing any of the [FUNCTION1] to [FUNCTION3] buttons displays the operations assigned to each button as shown below.

- HV DELAY
DELAY OFF/H DELAY/V DELAY/
HV DELAY
- BLUE ONLY
BLUE ONLY ON/BLUE ONLY OFF
- GAMMA SELECT
GAMMA STANDARD/GAMMA FILM/
GAMMA STUDIO/PST
- SD ASPECT
4:3/16:9
- SCAN
NORMAL SCAN/UNDER SCAN
- SUB WINDOW
SINGLE/FULL/PART/STILL
- WFM/VECTOR
WFM/VECTOR OFF/WFM Y ON/
WFM R ON/WFM G ON/WFM B ON/
VECTOR×1/VECTOR×2S/VECTOR×2/
VECTOR×4/VECTOR×8
- MARKER
MARKER OFF/4:3 MARKER/
13:9 MARKER/14:9 MARKER/
CNSCO2.39 MARKER/
CNSCO2.35 MARKER/
2:1 MARKER/VISTA MARKER/
95% MARKER/93% MARKER/
90% MARKER/88% MARKER/
80% MARKER/
xx% MARKER (xx % is a USER setting value of
80 % to 100 %)/MARKER ON
 - When the setting values of both 16:9 and 4:3
are set to other than OFF in the MARKER
menu settings, the setting value of 16:9 is
displayed in the first half section, and the
setting value of 4:3 is displayed in the second
half section.
- PIXEL TO PIXEL
PIXEL TO PIXEL OFF/
PIXEL TO PIXEL CENTER/
PIXEL TO PIXEL LT/
PIXEL TO PIXEL RT/
PIXEL TO PIXEL RB/
PIXEL TO PIXEL LB
- PIXEL POSITION
PIXEL TO PIXEL OFF/
PIXEL TO PIXEL CENTER/
PIXEL TO PIXEL LT/
PIXEL TO PIXEL RT/
PIXEL TO PIXEL RB/
PIXEL TO PIXEL LB
- FOCUS-IN-RED
FOCUS-IN-RED OFF/FOCUS-IN-RED ON
- ZEBRA
ZEBRA OFF/ZEBRA ON
- REAR TALLY
REAR TALLY OFF/ REAR TALLY ON
- LEVEL METER
METER OFF/METER 2CH/METER 4CH/
METER 8CH
- CROSS HATCH
CROSS HATCH HIGH/
CROSS HATCH LOW/
CROSS HATCH OFF
- MONO
MONO ON/MONO OFF
- TIME CODE
LTC/VITC/LUB/VUB/TC OFF
- BLACK MODE
BLACK MODE OFF/BLACK MODE ON
- CLOSED CAPTION
CC1/CC2/CC3/CC4/CC OFF
(SRV1/SRV2/SRV3/SRV4/SRV5/
SRV6/CC OFF)
 - * The displayed items differ depending on the
selection for CC TYPE.
- 2D ADJUST
2D ADJUST OFF/2D ADJUST ON

<Note>

WHITE BALANCE is switched to adjustment mode with a FUNCTION button, and the indication that indicates the operation is not displayed.

■ “HV DELAY”

This displays the blanking period. Each press of the button changes the display as follows: H blanking display → V blanking display → H and V blanking display → no blanking display.

Main Menu (continued)

■ “SUB WINDOW”

Opening the “SUB WINDOW” function splits the screen (main window) in two as shown below to enable comparison of a recorded still image with live video.

Use the “SUB WINDOW” setting (FULL, PART) in the “SYSTEM CONFIG” menu (page 34) to set up the function as shown below.

Press the button ([FUNCTION1] to [FUNCTION3] (page 38)) to which the “SUB WINDOW” function has been assigned to turn the function on and off.

- This assumes that the “SUB WINDOW” function has been assigned to any of the [FUNCTION1] to [FUNCTION3] buttons.

To setup “I-P MODE” (page 31), exit the “SUB WINDOW” function first.

• FULL

Resizes the main window to also display a second window (two sub-windows).

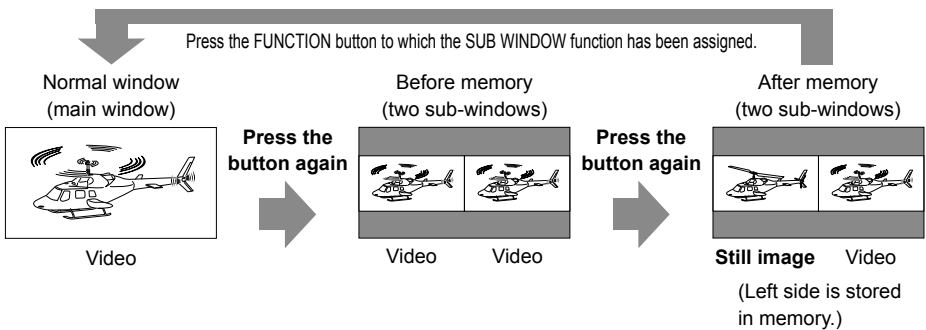

• PART

Resizes the main window to show only its center to also display a second image (two sub-windows).

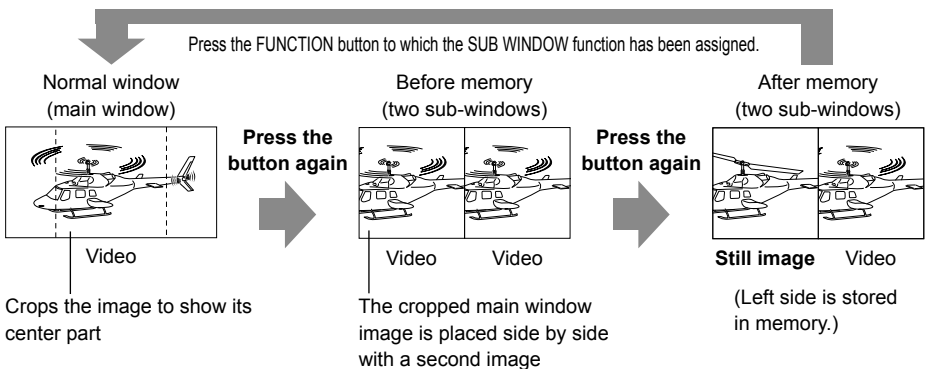

These examples show 16:9 aspect ratio images.

Note on FULL/PART selection

This function is designed to enable comparison of identical formats input to the same input terminal. Input of different formats via different input channels may distort the sub-window (left side, still image) or blanking could occur. However, input of an identical format signal to the input terminal during still image acquisition will display correctly.

Main Menu (continued)

■ “WFM/VECTOR”

The “WFM/VECTOR” function enables display of the waveform and vector display. Use “DISPLAY SETUP” in the main menu to select “WFM” and “VECTOR” display. (page 50)

Press the button ([FUNCTION1] to [FUNCTION3] (page 39)) to which the “WFM/VECTOR” function has been assigned to switch the display in the following order.

WFM/VECTOR OFF → WFM Y ON → WFM R ON → WFM G ON → WFM B ON → VECTOR (x1 to x8)

- This assumes that the “WFM/VECTOR” function has been assigned to any of the [FUNCTION1] to [FUNCTION3] buttons.

WFM is displayed in the order of the Y signal, R signal, G signal, and B signal.

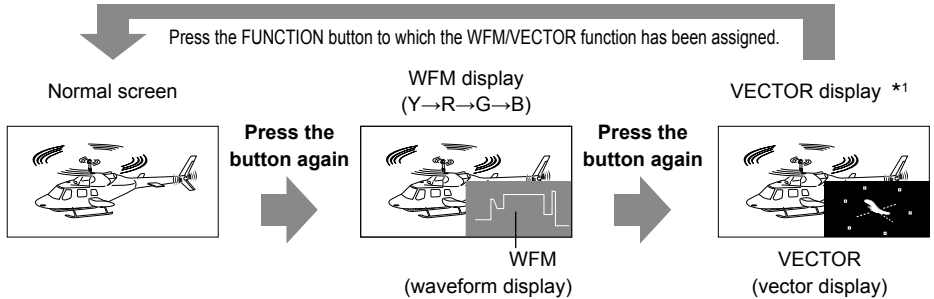

These examples show 16:9 aspect ratio images.

*1 Displayed only for SDI signal input.

- The scale display is as shown below.

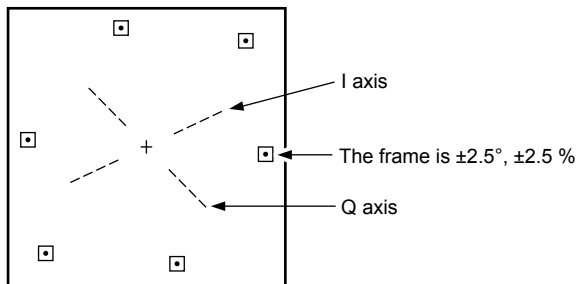
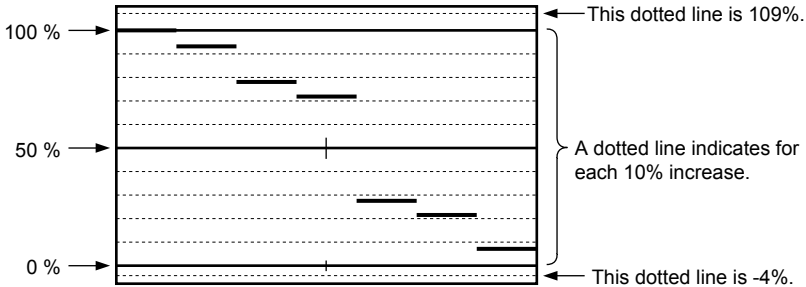

Main Menu (continued)

■ “PIXEL TO PIXEL” and “PIXEL POSITION”

The “PIXEL TO PIXEL” function allows you to check images at their actual pixel resolution (1080i/p signals only).

Press the button ([FUNCTION1] to [FUNCTION3] (page 38)) to which the “PIXEL TO PIXEL” function has been assigned to turn the function on. Then press the button ([FUNCTION1] to [FUNCTION3] (page 38)) to which the “PIXEL POSITION” function has been assigned to position the display of signals.

- This assumes that the “PIXEL TO PIXEL” and “PIXEL POSITION” functions have been assigned to any of the [FUNCTION1] to [FUNCTION3] buttons.

The underlined values are factory preset setting values.

Item	Settings	Description
PIXEL TO PIXEL *1*2	<u>OFF</u> ON	Sets whether to display the screen display size at the input signal size. <OFF> Not displayed. <ON> Displayed. Compatible formats 1080/60i/59i/50i/60p/59p/50p/30p/29p/ 25p/24p/23p/25PsF/24PsF/23PsF
PIXEL POSITION	<u>CENTER</u> LT RT RB LB	Positions the display of signals in PIXEL TO PIXEL mode. <CENTER> Center of the screen <LT> Left Top <RT> Right Top <RB> Right Bottom <LB> Left Bottom

*1 The following settings are disabled in PIXEL TO PIXEL mode.

- Setting “ANAMO” to “ON”, and setting “SCAN” to “UNDER” in “VIDEO CONFIG”
- Any “HV DELAY” setting in “FUNCTION”
- “MARKER” display

*2 Enabled during “SDI1”, “SDI2”, “HDMI”, “YP_BP_R” and “VF (VF-YP_BP_R)” input.

■ “PIXEL POSITION” display position sequence

PIXEL POSITION: ① → ② → ③ → ④ → ⑤ → ①

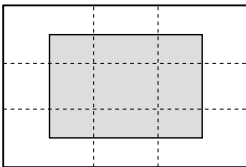

① CENTER

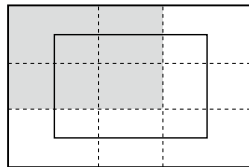

② LT (LEFT TOP)

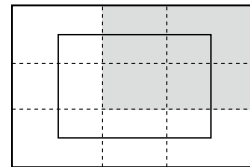

③ RT (RIGHT TOP)

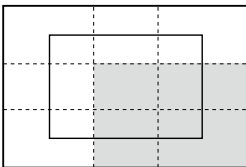

④ RB (RIGHT BOTTOM)

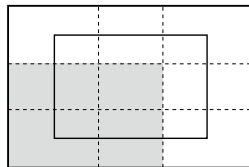

⑤ LB (LEFT BOTTOM)

Main Menu (continued)

■ “CROSS HATCH”

If the CROSS HATCH function is used, markers are displayed at regular vertical and horizontal intervals to facilitate, for example, easy composition. The marker line width is 1 dot / 1 line and the interval is 80 dots/80 lines or 40 dots/40 lines depending on the “SIZE” setting in the MARKER menu (page 27). Each press of the button (“FUNCTION1” to “FUNCTION3” (page 38)) to which the “CROSS HATCH” has been assigned turns the function on and off.

- This assumes that the “CROSS HATCH” function has been assigned to any of the [FUNCTION1] to [FUNCTION3] buttons.

Each press of the FUNCTION button to which the “CROSS HATCH” function is assigned changes the display as shown.

HD/SD (16:9) mode



Press the
button again

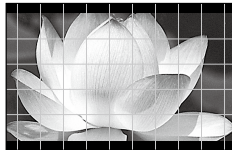

Press the
button again

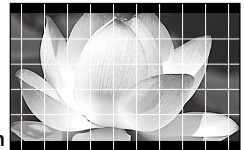

SD (4:3) mode



Dim cross hatch

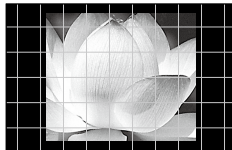

Bright cross hatch

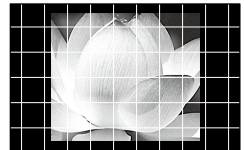

Press the button again (back to original image without cross hatch)

Main Menu (continued)

■ “FOCUS-IN-RED”

When the “FOCUS-IN-RED” function is used, the section that is being focused is displayed in an easy-to-understand red, making camera focus adjustments easy.

Each press of the button (“FUNCTION1” to “FUNCTION3” (page 38)) to which the “FOCUS-IN-RED” has been assigned turns the function on and off.

- This assumes that the “FOCUS-IN-RED” function has been assigned to any of the [FUNCTION1] to [FUNCTION3] buttons.

When the “FOCUS-IN-RED” function is displayed, the detection sensitivity level (0 - 30) can be changed with the F-IN-R knob. A higher numerical value results in lower detection sensitivity (outlines are displayed in red even when they are not in focus properly).

If you set CHROMA to 0 or assign "MONO" to another function button to switch to monochrome, the focus will become easier to check.

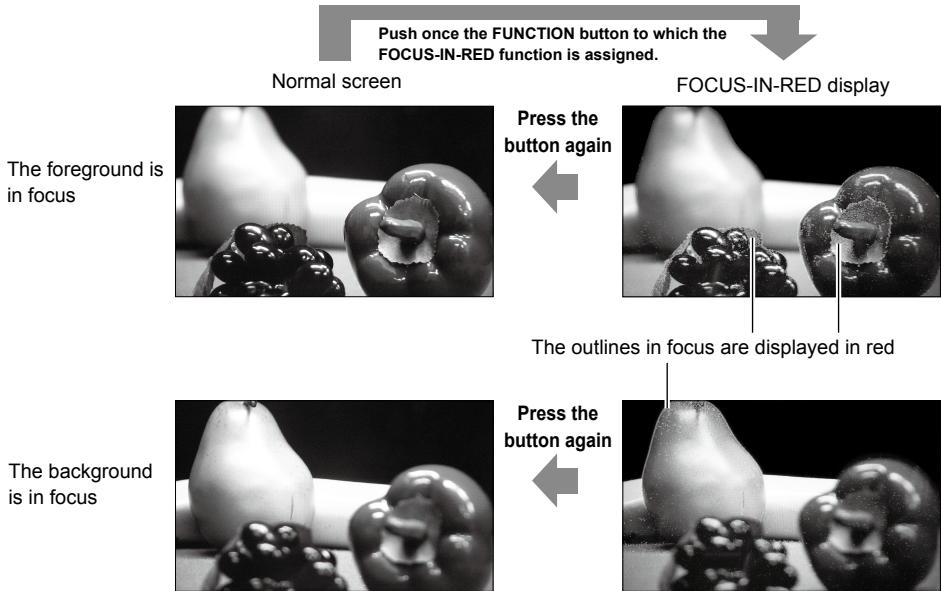

These examples show 16:9 aspect ratio images.

Main Menu (continued)

GPI

“GPI CONTROL” is used to enable and disable GPI functions and assign functions to each of the GPI terminal pins (page 62).

The underlined values are factory preset setting values.

Sub menu	Settings	Description
GPI CONTROL	<u>DISABLE</u> ENABLE	Enables and disables GPI functions <DISABLE> Disabled <ENABLE> Enabled
GPI1 - GPI8	<u>UNDEF</u> MARKER1 ON/OFF MARKER2 ON/OFF MARKER BACK HALF MARKER BACK BLACK CENTER MARKER INPUT SEL. VIDEO INPUT SEL. SDI1 INPUT SEL. SDI2 INPUT SEL. HDMI INPUT SEL. YP _B P _R INPUT SEL. VF INPUT SEL. INT SG SD ASPECT SCAN R-TALLY G-TALLY MONO GAMMA SEL. FILM GAMMA SEL. STDIO/PST PIXEL TO PIXEL FOCUS-IN-RED REMOTE STANDBY	Assigns functions to the GPI control terminal pins. The same items can be set to each terminal (page 62).

Note:

Operation may not be possible depending on the setting conditions.

Example: “SD ASPECT” operation when input signal is HD

Main Menu (continued)

INPUT SELECT

The underlined values are factory preset setting values.

Sub menu	Settings	Description
VIDEO	OFF <u>ON</u>	Sets or cancels VIDEO line for the INPUT button.*1
FORMAT	<u>AUTO</u> NTSC PAL	Used to select the format for VIDEO input.*2 <AUTO> NTSC or PAL is selected automatically. <NTSC> NTSC <PAL> PAL
NTSC SETUP	75 <u>00</u>	Selects NTSC setup level. <75> Select this function when using 7.5 % setup signals. (Adjusts the interior of the monitor to the 7.5 % setup level to suit the black level) <00> Select this when the signal is at a 0 IRE setup level.
SDI1	OFF <u>ON</u>	Sets or cancels SDI1 line for the INPUT button.*1
SDI2	OFF <u>ON</u>	Sets or cancels SDI2 line for the INPUT button.*1
HDMI	OFF <u>ON</u>	Sets or cancels HDMI line for the INPUT button.*1
Y_BP_R	OFF <u>ON</u>	Sets or cancels Y _B P _R line for the INPUT button.*1
COMPONENT LEVEL	<u>SMPTE</u> B75 B00	Selects Y _B P _R (component) signal input level. <SMPTE> Signal level complies with SMPTE and P _B and P _R are 0.7 V [p-p] at 100 % chroma. <B75> Select this when connecting a Betacam or similar device with a setup function. (Adjusts the interior of the monitor to the 7.5 % setup level to suit the black level) <B00> Select this when connecting a Betacam or similar device without a setup function.
VF	OFF <u>ON</u>	Sets or cancels VF line for the INPUT button.*1
VIDEO/Y_BP_R	VIDEO <u>Y_BP_R</u>	Used to select the VF input mode. <VIDEO> Selects the VIDEO signal. <Y _B P _R > Selects the Y _B P _R (component) signal.
SIGNAL TYPE	<u>HD</u> SD	Used to select the signal output from the camera. <HD> Selects the HD signal. <SD> Selects the SD signal.
INT SG	OFF <u>ON</u>	Sets or cancels INT SG line for the INPUT button.*1

*1 All of the seven input lines (VIDEO, SDI1, SDI2, HDMI, Y_BP_R, VF, and INT SG) cannot be set to OFF. If six of the input lines are set to OFF, the one remaining input line cannot be set to OFF.

*2 "AUTO" is the factory default, but select a specific format when there is risk that the input signal may be interrupted by outside noise.

Main Menu (continued)

AUDIO

Set the audio output and audio level meter.

The underlined values are factory preset setting values.

Sub menu	Settings	Description
SELECT L *1 *2	CH1 - CH8 (Factory default: CH1)	Selects embedded audio channel output to headphones (L).
SELECT R *1 *3	CH1 - CH8 (Factory default: CH2)	Selects embedded audio channel output to headphones (R).
LEVEL METER	<u>OFF</u> ON	Selects embedded audio level meter displayed. (page 20)
CH SELECT *4	<u>8CH</u> 4CH 2CH	Selects number of audio level meter channels.
POINT LINE	OFF <u>ON</u>	Switches the 0 dB line displayed on the meter on and off.
CH INFO.	OFF <u>ON</u>	Switches the channel displayed on the meter on and off.
HEAD ROOM *5	12dB 18dB <u>20dB</u>	Sets the display position of the reference point in the meter display.

*1 If the input signal is SD when CH5 to CH8 is selected:

The channel can be switched from CH5→CH1, CH6→CH2, CH7→CH3, and CH8→CH4. (The menu settings remain as is.)

*2 When an HDMI signal is input, the audio of CH1 is output to the headphones (L) regardless of the menu setting.

*3 When an HDMI signal is input, the audio of CH2 is output to the headphones (R) regardless of the menu setting.

*4 When an HDMI signal is input, the display becomes 2CH regardless of the menu setting. When an SD-SDI signal is input, the display becomes 4CH even if 8CH is selected in the menu.

*5 The factory preset setting value varies depending on the area set in "AREA SETTING" (page 35).

Main Menu (continued)

DISPLAY SETUP

The underlined values are factory preset setting values.

Sub menu	Settings	Description
WFM/VECTOR	<u>OFF</u> WFM Y WFM R WFM G WFM B VECTOR	Switches between "WFM/VECTOR" waveform and vector display. <WFM Y> - <WFM B> Displays waveforms. <VECTOR> Displays vector waveforms.*1
POSITION	LB <u>RB</u> RT LT	Selects the position for the "WFM/VECTOR" waveform display.*1 <LB> Left Bottom <RB> Right Bottom <RT> Right Top <LT> Left Top
VECTOR MODE	× 8 × 4 × 2 × 2S <u>× 1</u>	Enlarges vector waveforms.*1 < × 8> 8 × < × 4> 4 × < × 2> 2 × < × 2S> State in which displayed at scale of 1 x, and only waveforms enlarged to 2 x. < × 1> 1 ×
VECTOR SCALE	<u>100%</u> 75%	Determines the scale of vector waveform. <100%> Displays it at 100 % scale. <75%> Displays it at 75 % scale.
TIME CODE	<u>OFF</u> ON	Turns the time code display on and off.
MODE SELECT	<u>LTC</u> VITC LUB VUB	Selects time code display mode. <LTC> Displays linear time code (LTC). <VITC> Displays vertical interval time code (VITC). <LUB> Displays user bits included in LTC. <VUB> Displays user bits included in VITC.
CLOSED CAPTION	<u>OFF</u> ON	Turns closed caption display on and off.*2
CC TYPE	CEA-608 <u>CEA-708</u>	Selects the closed caption display mode. <CEA-608> Displays data compliant with CEA-608. <CEA-708> Displays data compliant with CEA-708.
CAPTION CHANNEL	CC4 CC3 CC2 <u>CC1</u>	Selects the closed caption display channel for when CEA-608.
CAPTION SERVICE	SRV6 SRV5 SRV4 SRV3 SRV2 <u>SRV1</u>	Selects the closed caption display service for when CEA-708.

*1 Opens the vector display during SDI signal input.

*2 Available during VIDEO input. Closed captions appear as bright lines on line 21 when closed caption is set to ON and underscan is also on.

Main Menu (continued)

CONTROL

The underlined values are factory preset setting values.

Sub menu	Settings	Description
CONTROL	<u>LOCAL</u> REMOTE	Selects operation. (with control clock) <LOCAL> Enables front panel operation <REMOTE> Enables remote operation (front panel operation is locked) *1
LOCAL ENABLE *2	<u>DISABLE</u> INPUT	Selects the disabled operation on the front panel when selecting "REMOTE" under "CONTROL". <DISABLE> Disables all front panel operations. <INPUT> All controls except [INPUT SELECT] and the volume knob are disabled.

- *1 The menu can be displayed when the lock is engaged.
 Only "CONTROL/LOCAL ENABLE" menu items are available when the lock is engaged.
 The picture adjusting knob is disabled when the lock is engaged.
 The FUNCTION buttons cannot be operated when the lock is engaged.
 The "LOCAL ENABLE" setting determines operations in lock mode.
 The key mark is displayed during lock engagement.



- *2 Only available when "REMOTE" is selected under "CONTROL."

HOURS METER

Sub menu	Settings	Description
OPERATION	XXXXXXh *1	Displays the number of hours it has been on.
LCD	XXXXXXh *1	Displays the number of hours that the backlight has been on.

- *1 "XXXXXX" indicates up to 262,800 hours (approx. 30 years). "OVER" is indicated when the number of hours is 262,800 or higher.

3D Assist Mode

The unit is equipped with 3D assist mode to provide support for shooting with a rig-type 3D camera system. The 3D assist mode has the following functions.

■ Image input method: SIMULTANEOUS (simultaneous method)R

Two types of image, one for the left eye (L) and one for the right eye (R), are input to the two SDI1 and SDI2 terminals.

- In 3D assist mode, the input is fixed to SDI1/SDI2 and the input line cannot be changed.
- An appropriate phase difference with the input signal of SDI2 is one that is up to $\pm 15 \mu\text{s}$ using the input signal of SDI1 as the reference.
- If the input signal formats of SDI1 and SDI2 are not identical or only one of the signals is input, the screen display will black out.

■ Assist functions

Assist Function Name	Screen Indication	Description
MIRROR	Side-by-side	Inverts the left and right and top and bottom of SDI2 (R) image to enable the basic adjustments of a 3D camera to be made. (Half-mirror type supported)
SHIFT	Overlay	Shifts SDI2 (R) image horizontally and vertically to enable the lens axis of the 3D camera to be checked.
COMPARISON	Side-by-side	Displays a halftone marker on the inside. A subject captured with only the camera of the L or R can be checked.
CONVERGENCE	Normal 1 screen display	Switches the L/R images automatically or manually to enable the convergence point to be checked.
COLOR	Overlay	Overlays the L/R images on a checkerboard pattern to enable the brightness or color offset to be checked.
ZOOM FOCUS	Side-by-side	Enlarges part of an image to enable the focus offset or zoom offset to be checked.
VERTICAL	Side-by-side	Displays the horizontal line markers to enable the vertical offset to be checked.
OVERLAY	Overlay	Displays the vertical line markers to enable the width of parallax to be checked.

■ How to switch to 3D assist mode

Select [3D ASSIST] in "2D/3D ASSIST" of the main menu. The MIRROR assist functions starts, and a status screen like the one shown in the figure on the rights appears.

- 1 Indicates the name of the assist function selected with adjusting knob 4.
- 2 Indicates the format of the signal input to SDI1.
- 3 Indicates the format of the signal input to SDI2.
- 4 Indicates the functions assigned to adjusting knobs 1 to 4. For the functions assigned to adjusting knobs 1 to 3, the definitions vary by assist function. The setting value of each function is confirmed at the point in time when the corresponding adjusting knob is operated. (pages 54 to 58)

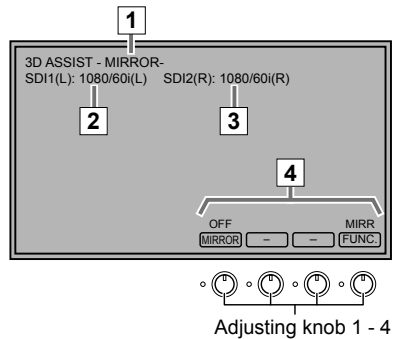

When you switch the mode to 3D assist mode, statuses **1** to **3** are displayed.

When you operate the function of **4**: If you press one of the adjusting knobs 1 to 4, statuses **1** to **3** disappear and status **4** is displayed. Status **4** continues to be displayed until the operation ends.

When you end the operation of **4**: If you press the FUNCTION3 button, status **4** disappears and statuses **1** to **3** are displayed.

3D Assist Mode (continued)

<Note>

- When a signal on which the LR information is superimposed is input to SDI1 such as when there is an AG-3DA1 connection, that LR information is displayed on the right side of the signal format. If L and R are incorrectly input, the LR information is displayed in yellow. If the LR information is input to SDI2 only, the LR information is not displayed on the right side of the signal format.

■ How to switch the assist function

Turn adjusting knob 4 (rightmost knob). Each turn clockwise switches the assist function in the order shown in the table above.

<Notes>

- When you switch to 3D assist mode, dedicated functions are assigned to the picture adjusting knobs and FUNCTION3 button in the control section on the front panel.
- When you want to make picture adjustments, switch to 2D mode.
- To make picture adjustments while still in 3D assist mode, press the FUNCTION3 button to turn ON the 2D picture quality adjustment mode, and then switch the function of the adjusting knob to the 3D assist mode function.
(If you turn OFF the 2D picture quality adjustment mode (2D ADJUST), the adjusting knob is reset to the 3D assist mode function.)
- The setting value is saved and the mode is returned to 3D assist mode when you press [ENTER] or when 10 seconds elapses after the setting value is changed.

■ How to return to 2D mode

Select [2D] in "2D/3D ASSIST" of the main menu.

3D Assist Mode (continued)

MIRROR (Left/Right and Top/Bottom inversion)

This function inverts just the left and right or top and bottom or both the left and right and top and bottom of the input signals of SDI2 (R) to enable the basic adjustments of a rig-type 3D camera system (half mirror type) to be made.



Screen:

The L/R 2 screens are shown side-by-side.

<Notes>

- Left and right inversion and top and bottom inversion are also reflected in other assist functions.
- The inversion setting information is even saved when the power is turned off.

The underlined values are factory preset setting values.

Sub menu	Operation	Settings	Description
MIRROR	Knob1 (turn)	OFF	Inverts the left and right and the top and bottom of the input signals on the SDI2 (R) side.
		LR	<OFF> Do not invert <LR> Invert Left and Right
		TB	<TB> Invert Top and Bottom
		LRTB	<LRTB> Invert Both Left and Right/Top and Bottom

SHIFT (Horizontal and Vertical Shift)

This function shifts the images of SDI2 (R) horizontally or vertically to enable you to overlay the images. You can check the lens axis of a rig-type camera system while checking the rotation offset of the image.



Screen:

L/R are overlaid in one screen.

<Note>

The setting information for shifting images with the SHIFT function is not memorized. The initial display state is restored when you switch to the COMPARISON function or another assist function.

The underlined values are factory preset setting values.

Sub menu	Operation	Settings	Description
H	Knob1 (turn)	-128 - <u>0</u> - 127	Shifts the images on the SDI2 (R) side horizontally.
V	Knob2 (turn)	-32 - <u>0</u> - 31	Shifts the images on the SDI2 (R) side vertically.

COMPARISON (Composition Check)

This function is for checking when the subject is captured with only the camera of one side.



Screen:

The L/R 2 screens are shown side-by-side, and a 70% size half-tone marker is shown inside each of the images.

<Assist Point>

If there is an image shown on either only the left or right, discomfort will be felt and stereoscopic vision will become difficult when the mode is set to 3D. Perform a comparison check of the parts of the images outside of the markers.

3D Assist Mode (continued)

CONVERGENCE (Convergence Check)

This function is for checking the subject's position at a fixed screen position in order to determine the depth position of the main subject.

Automatically or manually switch the SDI1 (L) image and SDI2 (R) image and then check the subject's position.



Screen:

Normal display of one screen

<Assist Points>

- The place at which the image does not change is the convergence point.
- If the camera adjustment (vertical or rotation direction position adjustment) is correct, the image at other than the convergence point will shift to the left/right target.

The underlined values are factory preset setting values.

Sub menu	Operation	Settings	Description
MODE	Knob1 (turn)	<u>MANU</u> AUTO	Selects the switching method of the L side image and R side image. <MANU> Manual switching <AUTO> Automatic switching
MANUAL	Knob2 (turn)	<u>L</u> R	Selects the image to display when the MODE menu is MANU. <L> Image of L side <R> Image of R side
SPEED	Knob3 (turn)	<u>SLOW</u> FAST	Selects the speed for when the MODE menu is auto switching. <SLOW> Every 1 second <FAST> Every 4 frames (When 720P: Every 8 frames)

COLOR (Color Check)

This function overlays and displays the SDI1 (L) image and SDI2 (R) image on a checkerboard pattern in one screen to enable you to check the brightness offset and color differences



Screen:

Overlay L/R on one screen.

<Assist Point>

If it is easy to see the borderline of the checkerboard pattern, the brightness or color of L/R images is offset.

The underlined values are factory preset setting values.

Sub menu	Operation	Settings	Description
SIZE	Knob1 (turn)	<u>128</u> <u>256</u>	Selects the checkerboard grid size for when overlaying the image of the L side and image of the R side. <128> The checkerboard grid consists of squares of 128 samples and 128 lines. <256> The checkerboard grid consists of squares of 256 samples and 256 lines.

3D Assist Mode (continued)

ZOOM FOCUS (Zoom and Focus Check)

This function enlarges part of an image to enable you to check the focus offset and zoom offset on the left and right, which tends to cause eye fatigue.



Screen:

The L/R 2 screens are shown side-by-side.

<Assist Point>

Expanding the parts that are not in focus makes it easy to check the focus of the left and right cameras.

The underlined values are factory preset setting values.

Sub menu	Operation	Settings	Description
ZOOM	Knob1 (turn)		Selects the signal display position of the enlarged image (PIXEL TO PIXEL). <Notes> <ul style="list-style-type: none"> • If you press F-IN-R (operation knob 2) and then set the FOCUS-IN-RED function to ON, the ZOOM menu is disabled and the FOCUS-IN-RED function is given priority. • If the FOCUS-IN-RED function is then set to OFF, the ZOOM menu is restored to the setting before the FOCUS-IN-RED was set to ON.
		(When 1080 signal input)	<OFF> Displays two screens side-by-side <C> Center of screen <LT> Top left of screen <CT> Top center of screen <RT> Top right of screen <RB> Bottom right of screen <CB> Bottom center of screen <LB> Bottom left of screen
		(When 720P signal input)	<OFF> Displays two screens side-by-side <C> Center of screen <L> Left of screen <R> Right of screen
F-IN-R	Knob2 (press)	<u>OFF</u> 0 - 30L 0 - <u>30R</u>	Turns OFF/ON the FOCUS-IN-RED function in the displayed screen. <OFF> Turns OFF the function. <0 to 30L> Displays the SDL1 (L) image side in 1-screen display and turns ON the function. <0 to 30R> Displays the SDL2 (R) image side in 1-screen display and turns ON the function. (The numerical value is the detection sensitivity level and is common to the left and right.)
	Knob3 (turn)	0 - <u>30L</u> or 0 - <u>30R</u>	Adjusts the detection sensitivity of FOCUS-IN-RED. (The numerical value turns green when sensitivity adjustment can be made.) A higher numerical value results in lower detection sensitivity (lack of sharpness). <0 to 30> The detection level, which is common to the left and right.

3D Assist Mode (continued)

VERTICAL (Vertical Offset Check)

This function enables you to operate two horizontal line markers to check the number of lines between markers in the displayed image and check vertical offset, which tends to cause eye fatigue.



- The number of lines of the displayed image is measured and then the number of lines between the two horizontal line markers is displayed at the bottom left of the screen.

Screen:

The L/R 2 screens are shown side-by-side, and two markers are shown.

<Assist Points>

- Displaying horizontal line markers makes it easy to check the left/right vertical offset.
- If the vertical offset becomes large, discomfort will be felt and stereoscopic vision will become difficult when the mode is set to 3D so make adjustments trying your hardest to eliminate camera vertical offset.

The underlined values are factory preset setting values.

Sub menu	Operation	Settings	Description
EXPAND	Knob1 (press)	<u>DISP</u> x1 x2	Selects the display screen. <DISP> Displays the full screen. <x1> (x1) Displays the screen with the actual number of pixels (PIXEL TO PIXEL) <x2> (x2) Expands the actual number of pixels to x2 in the vertical direction only and then displays the screen.
	Knob1 (turn)	<u>T</u> C B	Selects the display position for when the EXPAND setting is x1 or x2.*1 <T> Displays the top of the input image. <C> Displays the center of the input image. Displays the bottom of the input image.
MARKER1	Knob2 (turn)	0 - <u>384</u> - 767	Shifts the upper horizontal line marker up or down.*2
MARKER2	Knob3 (turn)	0 - <u>384</u> - 767	Shifts the lower horizontal line marker up or down.*2

*1 When the signal format is 720P, the display position of the image is not shifted when x1 display.

*2 The two horizontal line markers are each indicated by two lines, and the position of the upper line is indicated.

3D Assist Mode (continued)

OVERLAY (Parallax Check)

This function displays vertical line markers to enable you to check the width of parallax.

Overlay display



Screen:

L/R images are overlaid and shown on one screen, and vertical line markers are shown at 3% intervals across the horizontal image width.

- Vertical line markers can also be displayed in a gray screen in which the parallax portion is emphasized (gray display).

<Assist Point>

If the parallax is way too large, stereoscopic vision will become difficult when 3D images are viewed so check the width of parallax of the L side and R side images, using the width of the vertical line markers as a reference.

Gray display

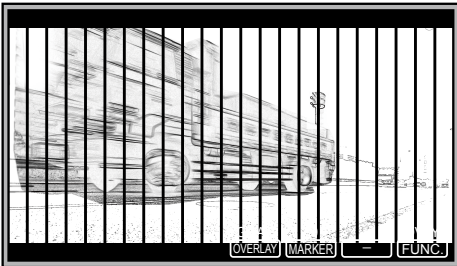

The underlined values are factory preset setting values.

Sub menu	Operation	Settings	Description
OVERLAY	Knob1 (turn)	STD GRAY	Selects overlay or gray display (displays image differences that emphasize the parallax portion). <STD> Overlay display <GRAY> Gray display (differences display)
MARKER	Knob2 (turn)	0 - <u>19</u> - 38	Shifts the vertical line marker in the horizontal direction.

Setting Item Restrictions

■ List of Setting Item Restrictions in 2D Mode

(✓: Can be set and the function is enabled)

Settings		Input CH		SD1/SDI2		HDMI			VIDEO	VF			Y _B P _R	
				SD	HD	640 x 480	SD	HD		VIDEO	Y _B P _R		SD	HD
		SD	HD						SD		HD			
2D/3D ASSIST		✓	✓	✓	✓	✓	✓	✓	✓	✓	✓	✓	✓	✓
MARKER	MARKER *1 *2	✓	✓	*3	✓	✓	✓	✓	*3	*3	*3	✓	✓	✓
	16:9 *1 *2	✓	✓	*3	✓	✓	✓	✓	*3	*3	*3	✓	✓	✓
	4:3 *1 *2	✓	✓	*3	✓	✓	✓	✓	*3	*3	*3	✓	✓	✓
	BACK *1 *2	✓	✓	*3	✓	✓	✓	✓	*3	*3	*3	✓	✓	✓
	CENTER *1 *2	✓	✓	*3	✓	✓	✓	✓	*3	*3	*3	✓	✓	✓
	GPI MARKER1 *1 *2	✓	✓	*3	✓	✓	✓	✓	*3	*3	*3	✓	✓	✓
	GPI MARKER2 *1 *2	✓	✓	*3	✓	✓	✓	✓	*3	*3	*3	✓	✓	✓
	MARKER TYPE *1 *2	✓	✓	*3	✓	✓	✓	✓	*3	*3	*3	✓	✓	✓
VIDEO CONFIG	CROSS HATCH	✓	✓	✓	✓	✓	✓	✓	✓	✓	✓	✓	✓	✓
	SIZE	✓	✓	✓	✓	✓	✓	✓	✓	✓	✓	✓	✓	✓
	GAMMA SELECT	✓	✓		✓	✓	✓	✓	✓	✓	✓	✓	✓	✓
	FILM GAMMA	✓	✓		✓	✓	✓	✓	✓	✓	✓	✓	✓	✓
	COLOR TEMP.	✓	✓	✓	✓	✓	✓	✓	✓	✓	✓	✓	✓	✓
	SHARPNESS MODE	✓	✓		✓	✓	✓	✓	✓	✓	✓	✓	✓	✓
	SHARPNESS H	✓	✓		✓	✓	✓	✓	✓	✓	✓	✓	✓	✓
	SHARPNESS V	✓	✓		✓	✓	✓	✓	✓	✓	✓	✓	✓	✓
	I-P MODE	✓	✓		✓	✓	✓	✓	✓	✓	✓	✓	✓	✓
	MONO	✓	✓		✓	✓	✓	✓	✓	✓	✓	✓	✓	✓
SYSTEM CONFIG	ANAMO *1 *2	*3	✓		*3	*3	*3	*3	*3	*3	*3	*3	*3	*3
	SD ASPECT *1 *2	✓	*3		✓	*3	✓	✓	✓	*3	✓	*3	✓	*3
	SCAN *1 *2	✓	✓		✓	✓	✓	✓	✓	✓	✓	✓	✓	✓
	SUB WINDOW	✓	✓		✓	✓	✓	✓	✓	✓	✓	✓	✓	✓
VF CONFIG	MENU POSITION	✓	✓	✓	✓	✓	✓	✓	✓	✓	✓	✓	✓	✓
	STATUS DISPLAY	✓	✓	✓	✓	✓	✓	✓	✓	✓	✓	✓	✓	✓
	BATTERY REMAIN	✓	✓	✓	✓	✓	✓	✓	✓	✓	✓	✓	✓	✓
	WARNING VOLTAGE	✓	✓	✓	✓	✓	✓	✓	✓	✓	✓	✓	✓	✓
	SETUP LOAD	✓	✓	✓	✓	✓	✓	✓	✓	✓	✓	✓	✓	✓
	SETUP SAVE	✓	✓	✓	✓	✓	✓	✓	✓	✓	✓	✓	✓	✓
	POWER ON SETUP	✓	✓	✓	✓	✓	✓	✓	✓	✓	✓	✓	✓	✓
	COLOR SPACE	✓	✓	✓	✓	✓	✓	✓	✓	✓	✓	✓	✓	✓
	POWER SAVE MODE	✓	✓	✓	✓	✓	✓	✓	✓	✓	✓	✓	✓	✓
	CALIBRATION	✓	✓	✓	✓	✓	✓	✓	✓	✓	✓	✓	✓	✓
FUNCTION	AREA SETTING	✓	✓	✓	✓	✓	✓	✓	✓	✓	✓	✓	✓	✓
	VF CONTROL	✓	✓	✓	✓	✓	✓	✓	✓	✓	✓	✓	✓	✓
	REAR TALLY	✓	✓	✓	✓	✓	✓	✓	✓	✓	✓	✓	✓	✓
	ZEBRA	✓	✓	✓	✓	✓	✓	✓	✓	✓	✓	✓	✓	✓
FUNCTION	FUNCTION1	✓	✓	✓	✓	✓	✓	✓	✓	✓	✓	✓	✓	*3
	FUNCTION2	✓	✓	✓	✓	✓	✓	✓	✓	✓	✓	✓	✓	✓
	FUNCTION3	✓	✓	✓	✓	✓	✓	✓	✓	✓	✓	✓	✓	✓
	FUNCTION DISPLAY	✓	✓	✓	✓	✓	✓	✓	✓	✓	✓	✓	✓	✓

(Continued on next page)

*1 This is not available when two screens are displayed with the SUB WINDOW function.

*2 This is not available in PIXEL TO PIXEL mode.

*3 Can be set but the function is disabled.

Setting Item Restrictions (continued)

(✓: Can be set and the function is enabled)

Settings		Input CH	SDI1/SDI2		HDMI			VIDEO	VF		YP _B P _R		
			SD	HD	640 x 480	SD	HD		VIDEO	YP _B P _R		SD	HD
										SD	HD		
GPI	GPI CONTROL	✓	✓	✓	✓	✓	✓	✓	✓	✓	✓	✓	
	GPI1 - GPI8	✓	✓	✓	✓	✓	✓	✓	✓	✓	✓	✓	
INPUT SELECT	VIDEO	✓	✓	✓	✓	✓	✓	✓	✓	✓	✓	✓	
	FORMAT	*3	*3	*3	*3	*3	✓	*3	*3	*3	*3	*3	
	NTSC SETUP	*3	*3	*3	*3	*3	✓	*3	*3	*3	*3	*3	
	SDI1	✓	✓	✓	✓	✓	✓	✓	✓	✓	✓	✓	
	SDI2	✓	✓	✓	✓	✓	✓	✓	✓	✓	✓	✓	
	HDMI	✓	✓	✓	✓	✓	✓	✓	✓	✓	✓	✓	
	YP _B P _R	✓	✓	✓	✓	✓	✓	✓	✓	✓	✓	✓	
	COMPONENT LEVEL	*3	*3	*3	*3	*3	*3	*3	*3	*3	✓	*3	
	VF	✓	✓	✓	✓	✓	✓	✓	✓	✓	✓	✓	
	VIDEO/ YP _B P _R	*3	*3	*3	*3	*3	*3	✓	✓	✓	*3	*3	
	SIGNAL TYPE	*3	*3	*3	*3	*3	*3	*3	✓	✓	*3	*3	
INT SG	✓	✓	✓	✓	✓	✓	✓	✓	✓	✓	✓		
AUDIO	SELECT L	✓	✓	✓	✓	✓	*3	*3	*3	*3	*3	*3	
	SELECT R	✓	✓	✓	✓	✓	*3	*3	*3	*3	*3	*3	
	LEVEL METER	✓	✓	✓	✓	✓	*3	*3	*3	*3	*3	*3	
	CH SELECT	✓	✓	*3	*3	*3	*3	*3	*3	*3	*3	*3	
	POINT LINE	✓	✓	✓	✓	✓	*3	*3	*3	*3	*3	*3	
	CH INFO.	✓	✓	✓	✓	✓	*3	*3	*3	*3	*3	*3	
HEAD ROOM	✓	✓	✓	✓	✓	*3	*3	*3	*3	*3	*3		
DISPLAY SETUP	WFM/VECTOR *1 *2	✓	✓		*4	*4	*4	*4	*4	*4	*4	*4	
	POSITION *1 *2	✓	✓		✓	✓	✓	✓	✓	✓	✓	✓	
	VECTOR MODE *1 *2	✓	✓		*3	*3	*3	*3	*3	*3	*3	*3	
	VECTOR SCALE *1 *2	✓	✓		*3	*3	*3	*3	*3	*3	*3	*3	
	TIME CODE	*3	✓	*3	*3	*3	*3	*3	*3	*3	*3	*3	
	MODE SELECT	*3	✓	*3	*3	*3	*3	*3	*3	*3	*3	*3	
	CLOSED CAPTION	✓	✓	*3	*3	*3	✓	*3	*3	*3	*3	*3	
	CC TYPE	✓	✓	*3	*3	*3	*3	*3	*3	*3	*3	*3	
	CAPTION CHANNEL	✓	✓	*3	*3	*3	✓	*3	*3	*3	*3	*3	
CAPTION SERVICE	*3	✓	*3	*3	*3	*3	*3	*3	*3	*3	*3		
CONTROL	CONTROL	✓	✓	✓	✓	✓	✓	✓	✓	✓	✓	✓	
	LOCAL ENABLE	✓	✓	✓	✓	✓	✓	✓	✓	✓	✓	✓	
HOURS METER	OPERATION	✓	✓	✓	✓	✓	✓	✓	✓	✓	✓		
LCD	✓	✓	✓	✓	✓	✓	✓	✓	✓	✓	✓		
IMAGE ADJUSTMENT	PEAKING	✓	✓		✓	✓	✓	✓	✓	✓	✓	✓	
	PHASE	✓	✓		✓	✓	✓	✓	✓	✓	✓		
	CHROMA	✓	✓		✓	✓	✓	✓	✓	✓	✓		
	BRIGHT	✓	✓		✓	✓	✓	✓	✓	✓	✓		
	CONTRAST	✓	✓		✓	✓	✓	✓	✓	✓	✓		
BACKLIGHT	✓	✓		✓	✓	✓	✓	✓	✓	✓	✓		

*1 This is not available when two screens are displayed with the SUB WINDOW function.

*2 This is not available in PIXEL TO PIXEL mode.

*3 Can be set but the function is disabled.

*4 VECTOR display is only shown when there is SDI input.

Setting Item Restrictions (continued)

■ List of Setting Item Restrictions in 3D Assist Mode

(✓: Can be set and the function is enabled)

Settings		Input CH	SDI1/SDI2 HD
2D/3D ASSIST			✓
MARKER	MARKER		*1
	16:9		*1
	4:3		*1
	BACK		*1
	CENTER		*1
	GPI MARKER1		*1
	GPI MARKER2		*1
	MARKER TYPE		*1
	CROSS HATCH		*1
SIZE		*1	
VIDEO CONFIG	GAMMA SELECT		✓
	FILM GAMMA		✓
	COLOR TEMP.		✓
	SHARPNESS MODE		✓
	SHARPNESS H		✓
	SHARPNESS V		✓
	I-P MODE		
	MONO		✓
	ANAMO		
	SD ASPECT		
SCAN			
SYSTEM CONFIG	SUB WINDOW		
	MENU POSITION		✓
	STATUS DISPLAY		✓
	BATTERY REMAIN		✓
	WARNING VOLTAGE		✓
	SETUP LOAD		✓
	SETUP SAVE		✓
	POWER ON SETUP		✓
	COLOR SPACE		✓
	POWER SAVE MODE		✓
	CALIBRATION		✓
	AREA SETTING		✓
	VF CONFIG	VF CONTROL	
REAR TALLY			✓
ZEBRA			✓
FUNCTION	FUNCTION1		*2
	FUNCTION2		*2
	FUNCTION3		
	FUNCTION DISPLAY		✓

Settings		Input CH	SDI1/SDI2 HD
GPI	GPI CONTROL		✓
	GPI1 - GPI8		✓
INPUT SELECT	VIDEO		
	FORMAT		
	NTSC SETUP		
	SDI1		
	SDI2		
	HDMI		
	YP _B P _R		
	COMPONENT LEVEL		
	VF		
	VIDEO/ YP _B P _R		
	SIGNAL TYPE		
	INT SG		
	AUDIO	SELECT L	
SELECT R			✓
LEVEL METER			✓
CH SELECT			✓
POINT LINE			✓
CH INFO.			✓
HEAD ROOM			✓
DISPLAY SETUP	WFM/VECTOR *3 *4		
	POSITION *3 *4		
	VECTOR MODE *3 *4		
	VECTOR SCALE *3 *4		
	TIME CODE		✓
	MODE SELECT		✓
	CLOSED CAPTION		
	CC TYPE		
	CAPTION CHANNEL		
	CAPTION SERVICE		
CONTROL	CONTROL		✓
	LOCAL ENABLE		✓
HOURS METER	OPERATION		✓
	LCD		✓

*1 Can be set but the function is disabled.

*2 Some functions do not operate in 3D assist mode (page 40).

*3 This is not available when two screens are displayed with the SUB WINDOW function.

*4 This is not available in PIXEL TO PIXEL mode.

REMOTE Specifications

This monitor permits remote operation via GPI/SERIAL terminal.

GPI terminal

GPI screen items correspond to the following terminals. Use the GPI menu to assign functions to each terminal (page 47).

Functions assigned to terminals are executed when GND (pin 5) is short-circuited (ON) or open (OFF).

■ Operating conditions

Level operation: Operates when GND is short-circuited.

Edge operation: Operates when GND changes from open to short-circuited.

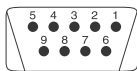

GPI Terminal (9P)

Pin number	Signal
1	GPI1
2	GPI2
3	GPI3
4	GPI4
5	GND
6	GPI5
7	GPI6
8	GPI7
9	GPI8

<Notes>

- When level operation is assigned to more than one terminal, the function operates as long as one of the terminals is short-circuited.
- Hold the edge operation for at least 0.2 seconds after the change.

Assigned item	Function	Operating conditions
UNDEF	Undefined (no function assigned)	—
MARKER1 ON/OFF *1	Switches marker display defined in “GPI MARKER1” (page 27) in the “MARKER” menu.	Level operation (Short-circuited: ON, Open: OFF)
MARKER2 ON/OFF *1	Switches marker display defined in “GPI MARKER2” (page 27) in the “MARKER” menu.	Level operation (Short-circuited: ON, Open: OFF)
MARKER BACK HALF *2	Reduces the brightness of the background outside the marker displayed in “GPI MARKER1” (page 27) to 50 %.	Level operation (Short-circuited: ON, Open: OFF)
MARKER BACK BLACK *2	Reduces the brightness of the background outside the marker displayed in “GPI MARKER1” (page 27) to 0 %.	Level operation (Short-circuited: ON, Open: OFF)
CENTER MARKER	Turns the center marker display on and off. (When other markers are displayed, this marker is superimposed on other markers.)	Level operation (Short-circuited: ON, Open: OFF)
SD ASPECT	Sets the aspect ratio for SD signal input. (Disabled during HD signal input)	Level operation (Short-circuited: 16:9, open: 4:3)
SCAN	Switches the scan mode between “UNDER” and “NORMAL”.	Level operation (Short-circuited: UNDER, Open: NORMAL)
GAMMA SEL. FILM	Switches the gamma curve to FILM mode.	Level operation (Short-circuited: FILM mode, Open: STANDARD mode)

(Continued on next page)

*1 When a 16:9 marker and a 4:3 marker are simultaneously selected and activated on a 16:9 aspect ratio display, both markers are displayed.

*2 When a 16:9 marker and a 4:3 marker are simultaneously displayed, the background of the marker selected by the 16:9 marker is controlled.

REMOTE Specifications (continued)

Assigned item	Function	Operating conditions
GAMMA SEL. STDIO/PST	Switches the gamma curve to STDIO/PST mode.	Level operation (Short-circuited: STDIO/ PST mode, Open: STANDARD mode)
INPUT SEL. VIDEO	Switches the input line to VIDEO.	Edge operation
INPUT SEL. SDI1	Switches the input line to SDI1.	Edge operation
INPUT SEL. SDI2	Switches the input line to SDI2.	Edge operation
INPUT SEL. HDMI	Switches the input line to HDMI.	Edge operation
INPUT SEL. YP_BP_R	Switches the input line to YP _B P _R .	Edge operation
INPUT SEL. VF	Switches the input line to VF.	Edge operation
INPUT SEL. INT SG	Switches the input line to INT SG.	Edge operation
MONO	Switches between color and monochrome (MONO).	Level operation (Short-circuited: monochrome, Open: color)
R-TALLY *3	Lights the red tally.	Level operation (Short-circuited: ON, Open: OFF)
G-TALLY *3	Lights the green tally.	Level operation (Short-circuited: ON, Open: OFF)
PIXEL TO PIXEL	Switches screen display between input size and display size.	Level operation (Short-circuited: ON, Open: OFF)
FOCUS-IN-RED	Displays the outlines of the subject that are in focus in red	Level operation (Short-circuited: ON, Open: OFF)
REMOTE STANDBY *4 *5	Sets remote standby (turns off the backlight, and turns off the power of devices that are not required).	Level operation (Short-circuited: ON, Open: OFF)

*3 When "R-TALLY" and "G-TALLY" simultaneously go on, the tally color changes to orange.

*4 When remote standby is set to ON, the CONT. and B.LIGHT LEDs on the front flash.

*5 If the GPI terminal to be assigned is set to a short-circuited state first and then MENU is operated to set this item, the backlight turns off and the screen display disappears, so MENU operation becomes unable to be checked. To change the setting of this item, be sure to set it when the GPI terminal is in the open state.

Restrictions

- SD ASPECT does not operate when the input signal is HD.
- The MARKER items do not operate when the input line of the signal is VF.
- SD ASPECT, SCAN, WFM/VECTOR, MARKER, PIXEL TO PIXEL, and PIXEL POSITION do not operate in SUB WINDOW mode.
- SCAN and MARKER do not operate in PIXEL TO PIXEL mode.
- GAMMA SELECT, SD ASPECT, SCAN, MARKER, and MONO do not operate when the input line of the signal is HDMI and the signal format is 640 x 480.

■ Priority of assigned functions

- When both "MARKER1" and "MARKER2" are activated at the same time, "MARKER1" has priority. However, when the display aspect ratio is 4:3, the "MARKER1" aspect ratio is 16:9 and the "MARKER2" aspect ratio is 4:3, "MARKER2" is displayed. In this case, the "MARKER2" background is controlled.
- When "MARKER BACK HALF" and "MARKER BACK BLACK" are activated at the same time, "MARKER BACK BLACK" has priority.
- INPUT SEL. are prioritized in the order of "INPUT SEL. VIDEO," "INPUT SEL. SDI1," "INPUT SEL. SDI2," "INPUT SEL. HDMI," "INPUT SEL. YP_BP_R," "INPUT SEL. VF," and "INT SG."
- When "GAMMA SEL. FILM" and "GAMMA SEL. STDIO/PST" are activated at the same time, "GAMMA SEL. FILM" has priority.

REMOTE Specifications (continued)

SERIAL terminal

External operations can be performed via the RS-232C interface.

The following diagram and the table on the following SERIAL terminal pin arrangement and connections. For details on systems using SERIAL, be sure to consult your dealer.

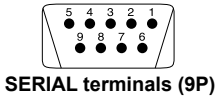

External Device Side		(Straight)	BT-LH910G Side	
Pin number	Signal		Pin number	Signal
1	N.C.		1	N.C.
2	RXD	←	2	TXD
3	TXD	→	3	RXD
4	DTR	→	4	DSR
5	GND	—	5	GND
6	DSR	←	6	DTR
7	RTS	→	7	CTS
8	CTS	←	8	RTS
9	N.C.		9	N.C.

■ Connectors and signals

Connector: D-SUB 9-pin (female)

Signal

Pin number	Signal	Description
1	N.C.	Not connected
2	TXD	Transmission data
3	RXD	Reception data
4	DSR	Connected inside
5	GND	Ground
6	DTR	Connected inside
7	CTS	Connected inside
8	RTS	Connected inside
9	N.C.	Not connected

■ Communication parameters

Signal level	RS-232C compliant
Synchro system	Asynchronous
Transfer rate	9600 bps
Parity	None
Data length	8 bit
Stop bit	1 bit
Flow control	None

■ Command format

STX (02h)	Command	:	Data	ETX (03h)
-----------	---------	---	------	-----------

- The command is the 3-character string starting with STX and ending with ETX.
- Append any data after the colon (:) following the command, as required.

■ Response formats

1. Setting command response

STX (02h)	Command	ETX (03h)
-----------	---------	-----------

2. Query command response

STX (02h)	Data	ETX (03h)
-----------	------	-----------

3. Error response

STX (02h)	Error codes	ETX (03h)
-----------	-------------	-----------

Error codes

ER001: Invalid command

ER002: Parameter error

REMOTE Specifications (continued)

■ Setting command

No	Command	Description	Data	Response
1	IIS	Input switch	0: SDI1 1: SDI2 2: VIDEO 3: YP _B P _R 5: VF 8: HDMI 9: INT SG	IIS
2	VPC	Image quality adjustment	CON00-60 : Contrast settings BRI00-60 : Brightness settings CRO00-60 : Chroma settings PHA00-60 : Phase settings VOL00-60 : Volume settings	VPC
3	OBO	Blue only	0: OFF 1: ON	OBO
4	OHV	HV Delay	0: OFF 1: H DELAY 2: V DELAY 3: HV DELAY	OHV
5	VBL	Backlight	000-100: Backlight setting	VBL
6	DCH	Cross hatch	0: OFF 1: LOW 2: HIGH	DCH
7	DCW	Cross hatch Size	0: 40 1: 80	DCW
8	DSD	Status display	0: CONTINUE 1: 3SEC OFF 2: OFF	DSD
9	DMK	Marker settings	<p>16:9 marker</p> <p>MK100: OFF MK101: 80 % MK102: 88 % MK103: 93 % MK104: 95 % MK105: 14:9 MK106: 13:9 MK107: 4:3 MK108: 90 % MK109: CNSCO 2.35 MK110: VISTA MK111: 2: 1 MK112: CNSCO 2.39 MK1 080 - MK1 100: range of 80 % - 100 %</p> <p>4:3 marker</p> <p>MK200: OFF MK201: 80 % MK202: 88 % MK203: 93 % MK204: 95 % MK208: 90 % MK2 080 - MK2 100: range of 80 % - 100 %</p> <p>Marker background</p> <p>BAK0: NORMAL BAK1: HALF BAK2: BLACK</p> <p>Center marker</p> <p>CMK0: OFF CMK1: ON</p>	DMK
10	MGM	Gamma selection	1: STANDARD 2: FILM 3: STUDIO/PST	MGM
11	MCT	Color temperature settings	00: D56 01: D65 02: D93 03: VAR1 04: VAR2 05: VAR3 10-73: USER0 - 63	MCT
12	MBM	Black mode	0: OFF 1: ON	MBM
13	VPC	Sharpness settings	SHP0: LOW SHP1: HIGH SHH00-30 Horizontal sharpness settings SHV00-30 Vertical sharpness settings	VPC

(Continued on next page)

REMOTE Specifications (continued)

No	Command	Description	Data		Response
14	MIP	IP mode settings	0: MODE1	1: MODE2	MIP
15	OMO	Monochrome settings	1: OFF	2: ON	OMO
16	MAS	SD aspect settings	0: 16:9	1: 4 :3	MAS
17	MSC	Scan settings	0: NORMAL	1: UNDER	MSC
18	MCO	Control settings	0: LOCAL	1: REMOTE	MCO
19	MLE	Remote operation settings	0: DISABLE	1: INPUT	MLE

■ Query command

No	Command	Description	Data	Response
1	QIS	Input selection		0: SDI1 1: SDI2 2: YP _B P _R 4: VIDEO 7: VF-YP _B P _R 8: VF-VIDEO 11: HDMI 12: INT SG
2	QPC	Image quality adjustment	CON: Contrast setting value	00-60
			BRI: Brightness setting value	00-60
			CRO: Chroma setting value	00-60
			PHA: Phase setting value	00-60
			VOL: Volume setting value	00-60
3	QBO	Blue only		0: OFF 1: ON
4	QBL	Backlight		000-100
5	QCH	Cross hatch		0: OFF 1: LOW 2: HIGH
6	QCW	Cross hatch Size		0: 40 1: 80
7	QMK	marker	MAK: Area marker *1	00: OFF 01: 80 % 02: 88 % 03: 93 % 04: 95 % 05: 14:9 06: 13:9 07: 4:3 08: 90 % 09: CNSCO 2.35 10: VISTA 11: 2: 1 12: CNSCO 2.39 80-100: USER80 - 100
			BAK: Background	0: NORMAL 1: HALF 2: BLACK
			CMK: Center marker	0: OFF 1: ON
8	QGM	Gamma		1: STANDARD 2: FILM 3: STUDIO/PST

(Continued on next page)

*1 When both 16:9 and 4:3 markers are displayed, the 16:9 marker state is returned.

REMOTE Specifications (continued)

No	Command	Description	Data	Response
9	QCT	Color temperature		00: D56 01: D65 02: D93 03: VAR1 04: VAR2 05: VAR3 10-73: USER0 - 63
10	QBM	Black Mode		0: OFF 1: ON
11	QPC	Sharpness	SHP : Sharpness mode	0: LOW 1: HIGH
			SHH : Horizontal sharpness value	00-30
			SHV : Vertical sharpness value	00-30
12	QIP	IP mode		0: MODE1 1: MODE2
13	QMO	Monochrome		1: OFF 2: ON
14	QAS	SD Aspect		0: 16:9 1: 4:3
15	QSC	Scan		0: NORMAL 1: UNDER
16	QFR	Format		01: 1080/60i 02: 1080/59.94i 03: 1080/50i, 1080/25PsF 04: 1080/30p 05: 1080/29.97p 06: 1080/25p 07: 1080/24p 08: 1080/23.98p 09: 1080/24PsF 10: 1080/23.98PsF 13: 720/60p 14: 720/59.94p 15: 576/50i 16: 480/59.94p 17: 480/59.94i 18: 576/50p 20: 1080/60p 21: 1080/59.94p 22: 1080/50p 23: 720/50p 51: 640×480 (60 Hz) 68: 640×480 (59.94 Hz) 00: NO SIGNAL FF: UNSUPPORT SIGNAL
17	QID	Model		BT-LH910

VF (viewfinder) Specifications

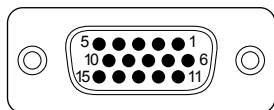

VF Terminal (15P)

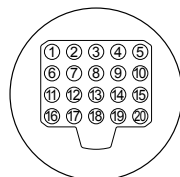

AJ-HPX3100G (Example)

This unit side VF Terminal

Pin number	Signal	Description
1	P _R	P _R signal
2	Y	Y signal
3	P _B	P _B signal
4	N.C.	Unused
5	GND	GND
6	P _R -GND	GND of P _R signal
7	Y-GND	GND of Y signal
8	P _B -GND	GND of P _B signal
9	ZEBRA-SW	ON/OFF of zebra signal
10	GND	GND
11	N.C.	Unused
12	VF-DATA	Serial data signal for serial-parallel conversion
13	VF-WR	Pulse signal for reading serial data for serial-parallel conversion
14	N.C.	Unused
15	VF-CLK	VF-CLK Serial data clock pulse signal

Camera side VF Terminal

Pin number	Description
15	VF-P _R
6	VF-Y
16	VF-P _B
-	-
20	UNREG-GND
5	VF-P _R -GND
7	VF-Y-GND
4	VF-P _B -GND
12	ZEBRA-SW
11	UNREG-GND
-	-
10	VF-DATA
9	VF-WR
-	-
8	VF-CLK
1	UNREG-12V
2	UNREG-12V
3	A9.0V
13	PEAKING
14	SPARE
17	MARKER-SW
18	FRONT-VR
19	VR-GND

<Note>

The 1, 2, 3, 13, 14, 17, 18, and 19 pins of the VF connector on the camera side do not connect to the VF connector on this unit side.

Error and Warning Displays

If for any reason an error occurs in this monitor, the LEDs above the picture adjusting knob flash at 1 second intervals to inform of the error/warning.

Error and Warning displays	Symptom	Remedy
Warning of improper operation status for the camera settings	ⓘ is displayed.	Check the setting values of the camera.*2
Near end warning *1	The voltage display flashes.	Replace with a fully charged battery.
Battery level error *1	“END BATTERY” is displayed for approximately 3 seconds before the power supply switches OFF.	Replace with a fully charged battery.

*1 Set the BATTERY REMAIN menu item of the SYSTEM CONFIG menu to ON.

*2 The condition to display differs depending on the type and settings of the camera used in combination with the unit. For details, see the instruction manual of the camera.

Maintenance

- To clean the cabinet or surface of the liquid crystal protection panel, gently wipe with a soft, dry cloth. If the surfaces are extremely dirty, use a soft cloth dipped in a weak detergent solution and then wrung-out to clean the surfaces, then use a dry cloth to finish. Water or similar substances getting inside the monitor can cause a malfunction.
- Never use alcohol, thinner or benzene to clean this unit.
Doing so would cause the surface of the monitor to become discolored, and cause paint to peel.
- Do not spray cleansers directly onto the monitor.
Water or similar substances getting inside the monitor can cause a malfunction.

Specifications

■ General

Input power: DC12 V (11.0 V - 17.0 V) Input current: 1.9A (DC12 V)

 is the safety information.

Dimensions (W × H × D): 230 mm × 214.5 mm × 170 mm (including stand)
[9-1/16 inches × 8-7/16 inches × 6-11/16 inches] (including stand)
230 mm × 183 mm × 78.5 mm (not including stand)
[9-1/16 inches × 7-3/16 inches × 3-7/8 inches] (not including stand)

Weight: 2.4 kg (5.29 lb) (including stand)
1.7 kg (3.75 lb) (not including stand)

Operating temperature: 0 °C to 40 °C (32 °F to 104 °F)
Operating humidity: 10 % to 85 % (no condensation)
Storage temperature: -20 °C to 60 °C (-4 °F to 140 °F)

■ Panel

Size: 23 cm (9.0 inch) (Effective display area)
Aspect ratio: 15:9
Number of pixels: 1280 × 768 (WXGA)
Display colors: Approx. 16,770,000 colors
View angle (contrast > 10:1): 176 ° up/down, 176 ° right/left

■ Input/output Connectors

VIDEO input: 1 line, BNC × 1 (Shared with the analog component Y input terminal)
Analog component (Y_PB_PR) input: 1 line, BNC × 3
(Of these, the Y input terminal is shared with the VIDEO input terminal)
HDMI input: 1 line, HDMI × 1 (Type A) (HDCP supported)
EMBEDDED AUDIO supported
VIERA Link not supported
SDI input: 2 line, BNC × 2
SMPTE274M/296M/259M-C/ITU-R BT.656-4 compliant
EMBEDDED AUDIO HD-SDI: SMPTE299M compliant
SD-SDI: SMPTE272M compliant
SDI output (active through): 2 line, BNC × 2
VF: D-SUB, 15 pins × 1
GPI: D-SUB, 9 pins × 1
SERIAL: D-SUB, 9 pins × 1
Headphone output: Stereo mini jack M3 × 1 32 Ω, level adjustable

Specifications (continued)

■ List of Signal Formats Supported in 2D Mode

(✓: Compatible)

Input Signal Format/ Status displays	VIDEO	VF-VIDEO	VF-YP _B P _R	YP _B P _R	SDI1* ⁴	SDI2	HDMI
NTSC	✓	✓					
PAL	✓	✓					
640×480 (59.94Hz)							✓
640×480 (60Hz)							✓
480/59.94i			✓	✓	✓	✓	
480/59.94p			✓	✓			✓
576/50i			✓	✓	✓	✓	
576/50p			✓	✓			✓
720/50p			✓	✓	✓	✓	✓
720/59.94p			✓	✓	✓	✓	✓
720/60p			✓	✓	✓	✓	✓
1035/59.94i * ¹			✓	✓	✓	✓	✓
1035/60i * ²			✓	✓	✓	✓	✓
1080/23.98PsF			✓	✓	✓	✓	
1080/24PsF			✓	✓	✓	✓	
1080/25PsF * ³			✓	✓	✓	✓	
1080/50i			✓	✓	✓	✓	✓
1080/59.94i			✓	✓	✓	✓	✓
1080/60i			✓	✓	✓	✓	✓
1080/23.98p					✓	✓	✓
1080/24p					✓	✓	✓
1080/25p					✓	✓	✓
1080/29.97p					✓	✓	✓
1080/30p					✓	✓	✓
1080/50p					✓		✓
1080/59.94p					✓		✓
1080/60p					✓		✓

*¹ When 1035/59.94i signal is input, displayed as 1080/59.94i. Other various marker displays will use the 1080/59.94i marker.

*² When 1035/60i signal is input, displayed as 1080/60i. Other various marker displays will use the 1080/60i marker.

*³ When 1080/25PsF signal is input, displayed as 1080/50i. Other various marker displays will use the 1080/50i marker.

*⁴ RGB444 and SDI422 (12 bit) are not supported.

Specifications (continued)

■ List of Signal Formats Supported in 3D Assist Mode

(✓: Compatible)

Input Signal Format/ Status displays	SDI1/2 (SIMUL)
720/50p	✓
720/59.94p	✓
720/60p	✓
1035/59.94i *1	✓
1035/60i *2	✓
1080/23.98PsF	✓
1080/24PsF	✓
1080/25PsF *3	✓
1080/50i	✓
1080/59.94i	✓
1080/60i	✓

*1 When 1035/59.94i signal is input, displayed as 1080/59.94i.

*2 When 1035/60i signal is input, displayed as 1080/60i.

*3 When 1080/25PsF signal is input, displayed as 1080/50i.

Specifications (continued)

■ Closed Caption Decoding

Supported Signals

Composite	NTSC, PAL
SD-SDI	480/59.94i, 576/50i
HD-SDI	1080/60i *1, 720/60p *1, 1080/50i, 720/50p, 1080/24PsF *1, 1080/25PsF, 1080/30p *1, 1080/24p *1, 1080/25p

Supported Standards

Composite	EIA/CEA-608 (VBI)
SD-SDI	EIA/CEA-608 (ANC)
HD-SDI	EIA/CEA-608 (708) , EIA/CEA-708

Supported Specifications (EIA/CEA-608)

Decode channels	CC1 - CC4 *2
Character	Standard Character, Special Character

Supported Specifications (EIA/CEA-708)

Caption service	Service #1 to #6
Character	G0 Code, G1 Code, Window Style*3, Pen Style*4

*1 The frame frequency of 1/1.001 is also supported.

*2 The XDS service is not supported.

*3 Window Style

Only justify LEFT is supported.

Only print direction LEFT-TO-RIGHT is supported.

Only scroll direction BOTTOM-TO-TOP is supported.

Word wrap is not supported.

Only the display effect SNAP is supported.

Fill color is not supported.

Fill opacity is not supported.

Border type is not supported.

*4 Pen Style

Pen size SMALL is supported.

Font style is 0

Only offset NORMAL is supported.

Italics is supported.

Underline is supported.

Only edge type UNIFORM is supported.

Foreground colors white, blue, green, yellow, cyan, red, gray, and magenta are supported.

Foreground opacity is not supported.

Background colors black and orange (orange is displayed when any color other than black is specified) are supported.

Only background opacity black (semi-transparent) is supported.

Weight and dimensions are approximate.

Specifications are subject to change without notice.

Specifications (continued)

■ INT SG (Internal chart for adjustment)

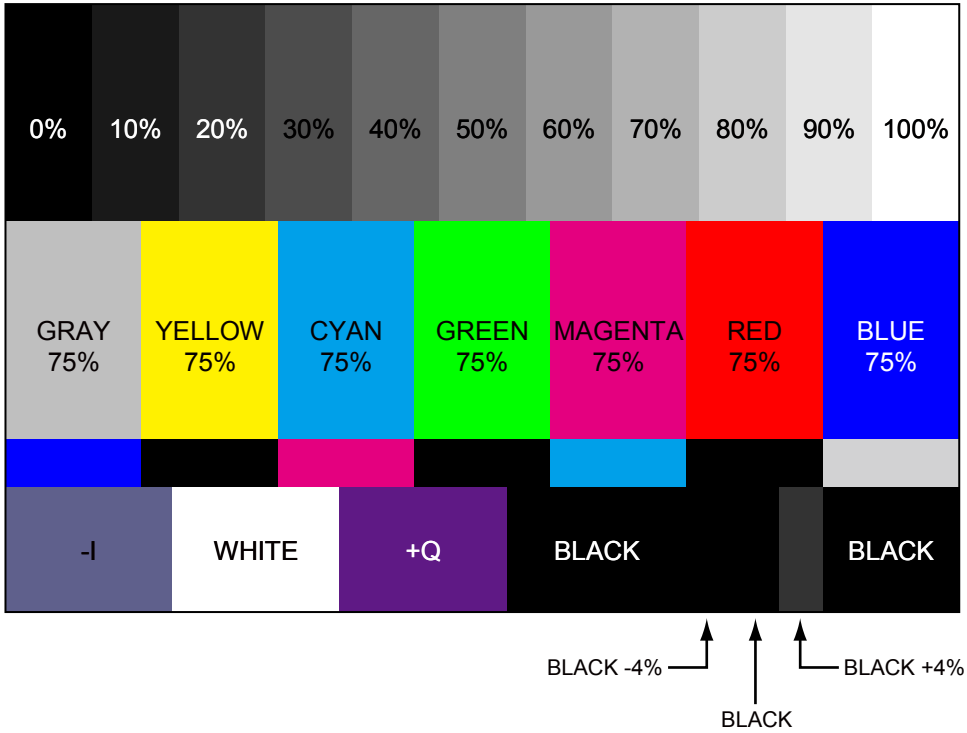

Information on Disposal for Users of Waste Electrical & Electronic Equipment (private households)



This symbol on the products and/or accompanying documents means that used electrical and electronic products should not be mixed with general household waste.

For proper treatment, recovery and recycling, please take these products to designated collection points, where they will be accepted on a free of charge basis. Alternatively, in some countries you may be able to return your products to your local retailer upon the purchase of an equivalent new product.

Disposing of this product correctly will help to save valuable resources and prevent any potential negative effects on human health and the environment which could otherwise arise from inappropriate waste handling. Please contact your local authority for further details of your nearest designated collection point.

Penalties may be applicable for incorrect disposal of this waste, in accordance with national legislation.

For business users in the European Union

If you wish to discard electrical and electronic equipment, please contact your dealer or supplier for further information.

Information on Disposal in other Countries outside the European Union

This symbol is only valid in the European Union.

If you wish to discard this product, please contact your local authorities or dealer and ask for the correct method of disposal.

Panasonic Corporation

Web Site: <http://panasonic.net>

Panasonic Solutions Company

3 Panasonic Way, Secaucus, NJ 07094 Tel: 877-803-8492
www.panasonic.com/broadcast e-mail: MediaProServices.PSC@us.panasonic.com

Panasonic Canada Inc.

5770 Ambler Drive, Mississauga, Ontario L4W 2T3 Tel: 905-624-5010

Panasonic de México S.A. De C.V.

Casa Matriz: Felix Cuevas No.6 Piso 2 y 3 Col. Tlacoquemecatl Del Valle Del.Benito Juárez, México, D.F., C.P.03200
Tel: 55-5488-1000 Fax: 55-5575-6783

Panasonic Latin America, S.A.

P.O.Box 0816-03164 Panama, Republic of Panama Tel: +507-229-2955 Fax: 507-229-5352

Panasonic do Brasil Ltda.

Rua Cubatão, 320-6º andar-Paraiso CEP 04013-001- São Paulo -SP Tel: 11-3889-4000 Fax: 11-3889-4004

파나소닉 코리아 주식회사 (PKL)

서울특별시 서초구 서초동 1553-5 오피런스 17 층
서비스 문의 : 02-533-8452
<http://panasonic.kr>

パナソニック株式会社 AVC ネットワークス社 イメージング事業グループ

〒 571-8503 大阪府門真市松葉町 2 番 15 号 ☎ (06) 6901-1161

